

SH. 1
OF 1

CAT NO

PT06632-8

CUSTOMER DIMENSIONS

DO NOT
SEPARATE
PRINT FROM
WORK

LOT NO

OPER

TOOLS

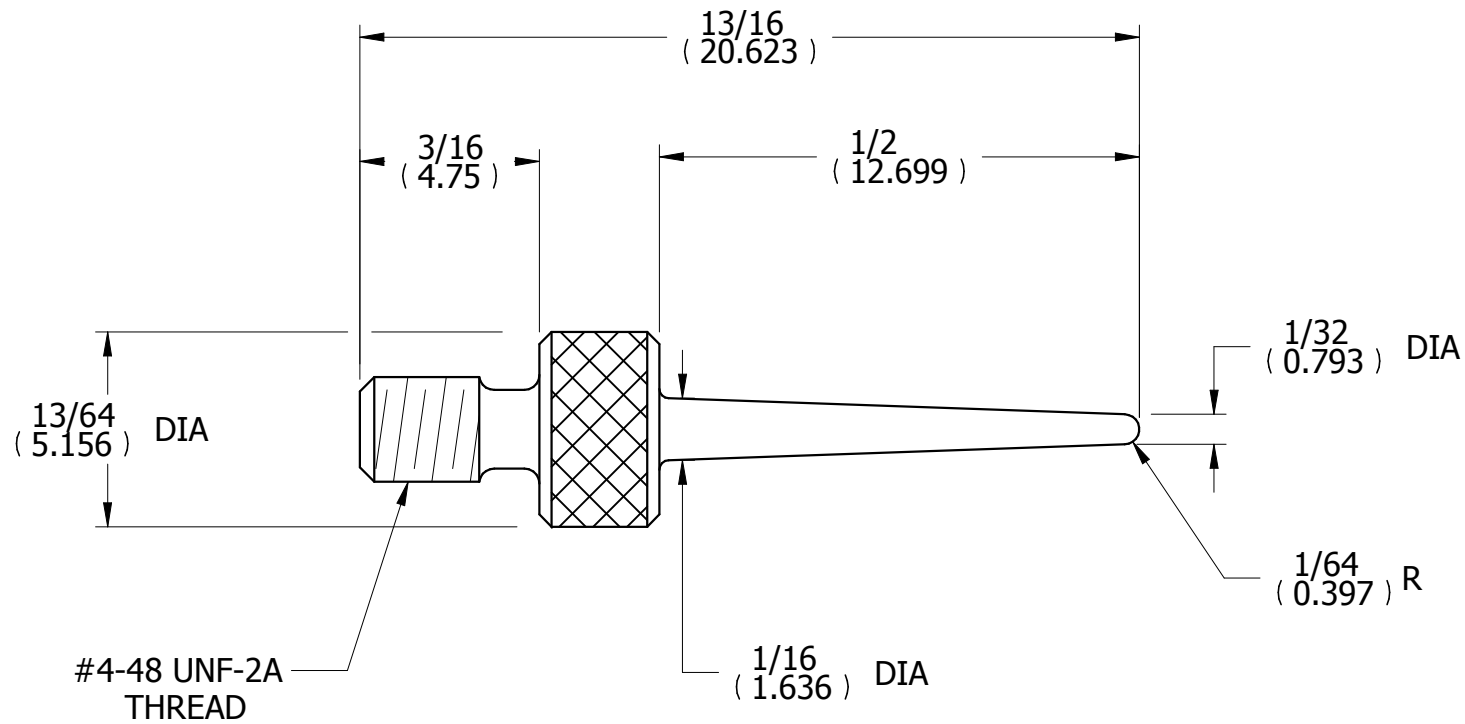

| | | | |
|--|--|--|--|
| | | | |
| | | | |
| | | | |
| | | | |
| | | | |
| | | | |
| | | | |
| | | | |

| REV | DESCRIPTION | DATE | BY |
|-----|-------------|------|--------------|
| DR | CAP | CHK | DATE 10/7/15 |

CONTACT POINT

THE L.S. STARRETT CO.
ATHOL, MASS.

FRACTIONAL TOLERANCE $\pm 1/64$ UNLESS OTHERWISE NOTED