



ALLIED MACHINE & ENGINEERING

Holemaking Solutions for Today's Manufacturing



Boring



Reaming



Burnishing



Threading

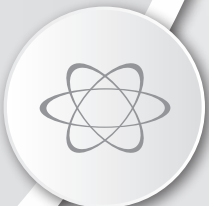

Specials



4TEX™ Drill

► *DRILLING*

Indexable Insert Drilling System

North America

Allied Machine
120 Deeds Drive
Dover, OH 44622
United States

Allied Machine
485 West 3rd Street
Dover, OH 44622
United States

ThreadMills USA™

4185 Crosstowne Ct #B
Evans, GA 30809
United States

Superion™

1285 S Patton St.
Xenia, OH 45385
United States

Europe

Allied Machine Europe
93 Vantage Point
Pensnett Estate
Kingswinford
West Midlands
DY6 7FR, United Kingdom

Wohlhaupter® GmbH

Maybachstrasse 4
Postfach 1264
72636 Frickenhausen
Germany

Asia

Wohlhaupter® India
B-23, 2nd Floor
B Block Community Centre
Janakpuri, New Delhi - 110058
India



Allied Machine & Engineering is a worldwide leader in holemaking and finishing solutions. We are committed to providing practical and dependable solutions to our customers through innovative designs and superior customer and technical support.

We continue to expand our product offering in order to provide new and different solutions. With Field Sales Engineers located around the world, we position ourselves to provide technical support on site, right at your spindle.



www.alliedmachine.com

The Foundation

Since 1941, Allied Machine & Engineering has provided dependable and practical holemaking solutions to the world. What was once a small job shop in Ohio is now a worldwide leader in cutting tool technology. With three manufacturing facilities in Ohio, one in Georgia, another in Germany, and headquarters in both the United States and Europe, Allied Machine is positioned to bring innovative solutions and technical expertise directly to the customers' hands.



The Beginning

Harold E. Stokey founded Allied Machine & Engineering to aid the war effort, manufacturing taper bearing lock nuts for the production of M1 tanks. Years later, after a sales meeting gone wrong, Stokey possessed a warehouse stocked with spade drill inserts. He set forth into the industry that would become Allied Machine's thriving identity: holemaking.



The T-A®

When Harold's son, William H. Stokey, became the president and CEO, he developed the Throw Away, or T-A, spade drill insert system. The T-A revolutionized the holemaking industry, launching Allied Machine ahead of the competition. Since then, numerous innovations and advancements have been created from the T-A's inspiration.



The Innovation

Since the development of the T-A, Allied Machine has expanded its product offering to support a vast range of customer applications, including large diameter and deep hole drilling, boring, reaming, burnishing, porting, and threading.

The People

Allied Machine understands that high quality products are only one facet of success. Our customer support is crucial to what we do, and that's why we make sure the best engineers and customer service associates are in place to assist our customers around the world.

The Future

With over 75 years of experience, Allied Machine has encountered the challenges of growth and success. By investing in cutting edge technology and the brightest and sharpest minds, our knowledge and capabilities continue to expand and grow every day.



Steve Stokey
Executive Vice President

William H. Stokey
President and CEO

Mike Stokey
Executive Vice President



Holemaking Solutions for Today's Manufacturing

WOHLHAUPTER®



SUPERION™

CRITERION™

Replaceable Insert Drills

- Reduce costs by decreasing set-up time and utilizing a single holder for the lives of multiple inserts
- Provide flexibility to quickly switch between inserts with different geometries
- Products:
 - GEN3SYS® XT | GEN3SYS® XT Pro
 - Original T-A® | GEN2 T-A®
 - High Performance | Universal



Indexable Insert Drills

- Protect your investment and reduce your inventory with replaceable cartridges that allow the same holder to be used repeatedly
- Indexable inserts increase productivity and tool life while reducing costs
- Products:
 - 4TEX™ Drill
 - Revolution Drill®
 - Opening Drill®

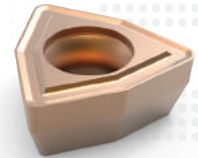

Replaceable / Indexable Insert Drills

- Allow for higher spindle speeds and take advantage of the power curve on modern CNC machines
- Achieve maximum penetration rates in deep hole drilling applications
- Holders cover a range of sizes with the replaceable heads determining the cutting diameter
- Products:
 - APX Drill



Solid Carbide Drills

- Offer greater strength and stability when drilling tougher materials
- Available in diameters from 3mm - 50mm
- Can be made-to-order specifically for your application (Superion™ quoted specials)
 - ASC 320®
 - Superion™



Structural Steel Solutions



- Deliver outstanding performance and durability in structural steel applications
- Designed to produce optimal results in difficult-to-machine materials
- Available in multiple lengths and diameters
- T-A® style drills have different insert geometry options to improve performance depending on material
- Products:
 - Original T-A® | GEN2 T-A®
 - GEN3SYS® XT

BTA (STS) Machining Solutions

- The internal ejection system flushes chips and debris from the hole with no interference to the cutting process
- Utilizes the advantages of the T-A® drill insert
- Designed to significantly increase penetration rates over brazed heads and traditional gun drills
- Products:
 - BT-A Drill



Hydraulic Port Contour Cutters

- Save significant time and money by performing four processes in one step
- Replaceable insert design reduces costs, inventory, and set-up times
- Available in 4 industry specifications:
 - Imperial: SAE J-1926
 - Metric: ISO 6149-1:2006
 - Military: SAE AS5202
 - John Deere: JDS-G173.1
- Products:
 - AccuPort 432®



Enhanced Special Drilling Capabilities

- Allied Machine Engineers are available to meet with you to evaluate your application and recommend the best solution for you
- Special drilling solutions can incorporate advanced features such as adjustable diameter locations, multiple steps, additional coolant designs, special lengths and diameters, and more
- Special drills can drastically reduce your cost-per-hole and increase your overall productivity by eliminating multiple processes and increasing tool life



WOHLHAUPTER®

High Precision Boring Systems

- Designs available for high volume applications that increase rigidity to improve performance
- Versatile boring heads that are flexible with changing applications while maintaining excellent performance
- Provides high precision with absolute repeatability to ensure every part is held to tolerance
- Offers an industry leading modular shank connection that maintains rigidity and reduces inventory on your boring system
- Available with both digital and analog settings
- Products:
 - Wohlhaupter® Boring Tools



CRITERION™

Modular Boring Systems

- The modular capabilities are ideal for use across multiple different projects
- Offers versatile boring heads suitable for all job shops and tooling rooms
- Provides an economical solution for low volume and/or short-term production applications
- Offers both rough and finish boring solutions
- Products:
 - Criterion™ Boring Tools

S.C.A.M.I.®

Expandable Reaming Solutions

- Expandable cutting diameters accommodate for wear, which extends tool life
- Replaceable cutting heads and rings reduce waste and improve production time versus solid high speed steel and carbide reamers
- Hold tight tolerances to ensure processes are performed to accurate specifications
- Reduce tooling costs because many items are available for recondition
- Products:
 - ALVAN® Reamers



S.C.A.M.I.®

Roller Burnishing Solutions

- Produce excellent surface finishes
- Provide accurate size control
- Increase surface hardness
- Solutions for both through hole and blind hole applications
- Products:
 - S.C.A.M.I.® Roller Burnishing Tools



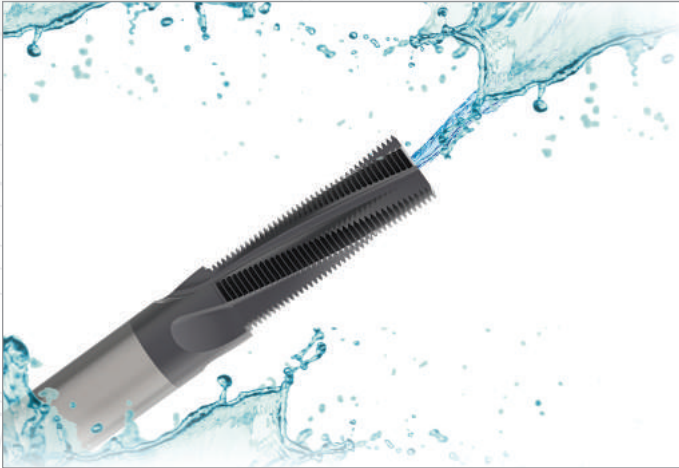

Solid Carbide Thread Mills

- Available with coolant through options
- Cover a wide range of thread forms
- Provide optimal solutions for both high production projects and short-run applications
- Products
 - AccuThread™ 856
 - ThreadMills USA



Replaceable Insert Thread Mills

- 3 insert lengths are available that cover a wide range of thread forms
- Holders can utilize inserts with different pitches and thread forms
- Repeatability is achieved by both the bolt-in style and the pin style locking systems
- Increase tool life by 25 - 50% with Allied Machine's AM210® coating
- Products
 - AccuThread™ 856: Bolt-in Style
 - AccuThread™ 856: Pin Style

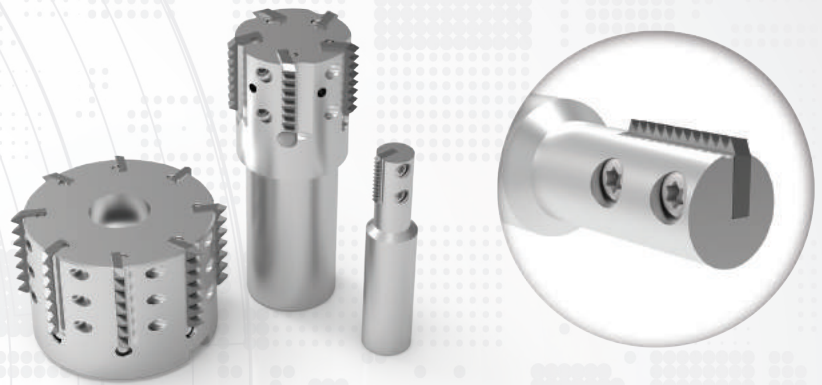

SPECIAL CAPABILITIES

When it comes to designing and developing special solutions for customers, Allied Machine is the top choice. If your application requires special tooling, give us a call. Our engineered specials are developed by the brightest engineers in the industry. Most of our standard tooling can be altered as specials, or we can create entirely new concepts for particularly unique applications.

One special tooling solution is Insta-Quote™, the online system that allows you to design your own special tooling 24/7. Receive a quote and drawings within minutes just by following the steps.

And with the addition of Superior™ technology and capabilities, we can customize made-to-order solid carbide tools to achieve optimal results for your applications.

Whatever your application, Allied Machine has the answer.



Insta-Quote™ 

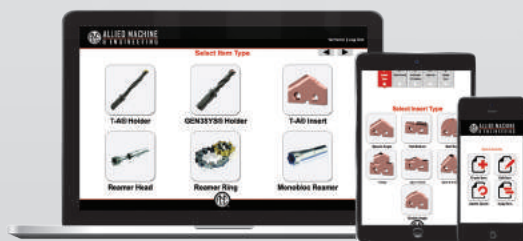

 SUPERION™



4TEX™ Drill

Indexable Carbide Insert Drilling System

▶ **Diameter Range:** 0.472" - 1.850" (12.00mm - 47.00mm)



Don't Let Your Machine Slow You Down

The 4TEX indexable carbide drill provides increased penetration rates on light duty machines due to the single effective design. With twisted coolant outlets and increased core strength, the design provides improved hole size and finish.

The 4 sided 4TEX inserts are designed to use 2 sides in the center pocket and 2 sides in the periphery pocket for an improved cost-per-hole. With insert geometries available for all ISO material classes and a robust body design, the 4TEX is suited for your difficult applications.

Improved hole size and finish	Superior chip evacuation	Increased penetration rates
-------------------------------	--------------------------	-----------------------------

Applicable Industries

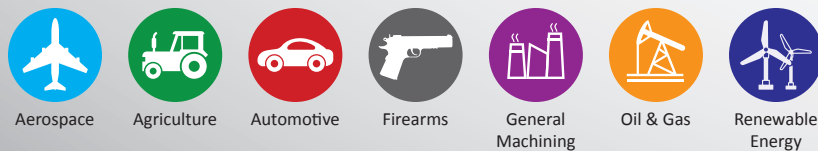

Your safety and the safety of others is very important. This catalog contains important safety messages. Always read and follow all safety precautions.



This triangle is a safety hazard symbol. It alerts you to potential safety hazards that can cause tool failure and serious injury.

When you see this symbol in the catalog, look for a related safety message that may be near this triangle or referred to in the nearby text.

There are safety signal words also used in the catalog. Safety messages follow these words.

WARNING

WARNING (shown above) means that failure to follow the precautions in this message could result in tool failure and serious injury.

NOTICE means that failure to follow the precautions in this message could result in damage to the tool or machine but not result in personal injury.

NOTE and **IMPORTANT** are also used. These are important that you read and follow but are not safety-related.

Visit www.alliedmachine.com for the most up-to-date information and procedures.

Reference Icons

The following icons will appear throughout the catalog to help you navigate between products.



Setup / Assembly Information

Detailed instructions and information regarding the corresponding part(s)

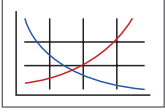

Recommended Cutting Data

Speed and feed recommendations for optimum and safe drilling

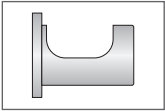

Eccentric Sleeves

Refers to the corresponding eccentric sleeve for the holder

Series	Diameter Range	
	Imperial (inch)	Metric (mm)
03	0.472 - 0.531	12.00 - 13.49
04	0.532 - 0.610	13.50 - 15.49
05	0.611 - 0.728	15.50 - 18.49
06	0.729 - 0.866	18.50 - 21.99
07	0.867 - 1.043	22.00 - 26.49
09	1.044 - 1.259	26.50 - 31.99
11	1.260 - 1.535	32.00 - 38.99
14	1.536 - 1.850	39.00 - 47.00

Introduction Information

Product Overview 2 - 3
 Insert Information 4
 Product Nomenclature 5

Drill Series

03 Series 6 - 7
 04 Series 8 - 9
 05 Series 10 - 11
 06 Series 12 - 13
 07 Series 14 - 15
 09 Series 16 - 17
 11 Series 18 - 19
 14 Series 20 - 21

Eccentric Sleeves 22

Technical Information

Diameter Adjustment 23
 Center Height Alignment 24 - 25

Recommended Cutting Data

Imperial (inch) 26
 Metric (mm) 27

Insert Geometry Recommendations 28

Troubleshooting Guide 29

Guaranteed Demo Application 30

Product Overview

4TEX Drill *Advantages*

- ✓ **Improved tool holder rigidity and increased reliability**
provided by the stronger core
- ✓ **Superior chip evacuation**
provided by the 2 twisted coolant holes
- ✓ **Improved hole size**
from the stronger core and increased coolant volume
- ✓ **Longer tool life**
provided by the 4-sided insert design
- ✓ **Simplified tooling selection**
with ISO-specific insert geometry/coating combinations
- ✓ **Increased penetration rates**
due to single effective cutting on light duty machines

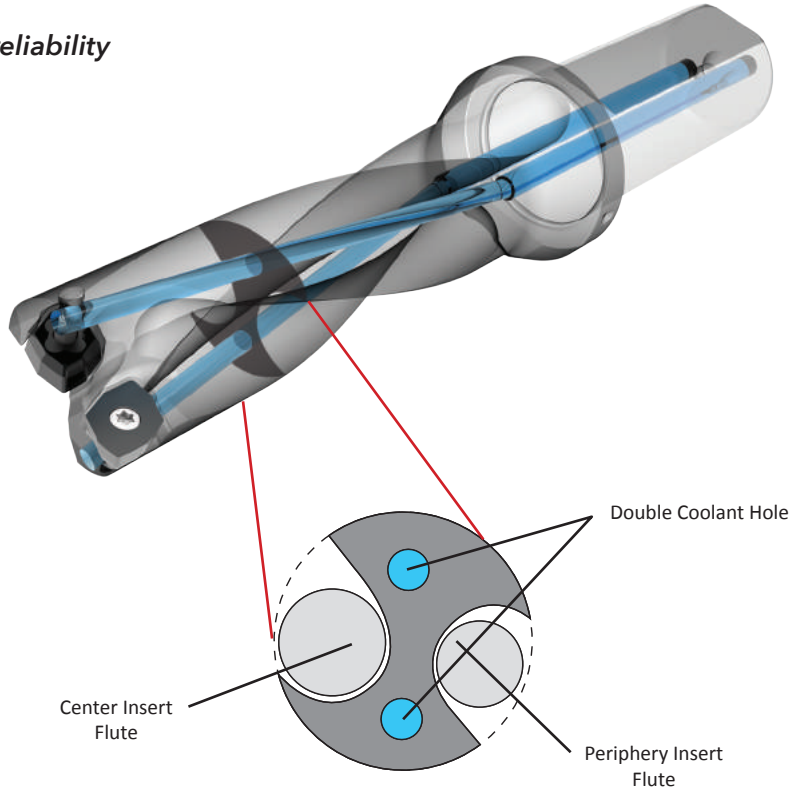

STABLE & EFFICIENT

- The 2 twisted coolant holes allow the core to remain intact, making the core thicker and stronger.
- The dual coolant outlets increase the coolant volume, which improves the chip evacuation and improves the hole size.
- The flute space of the internal cutting edge side (where chips get stuck most often) is 1.6x larger than typical IC drills.

LONGER TOOL LIFE

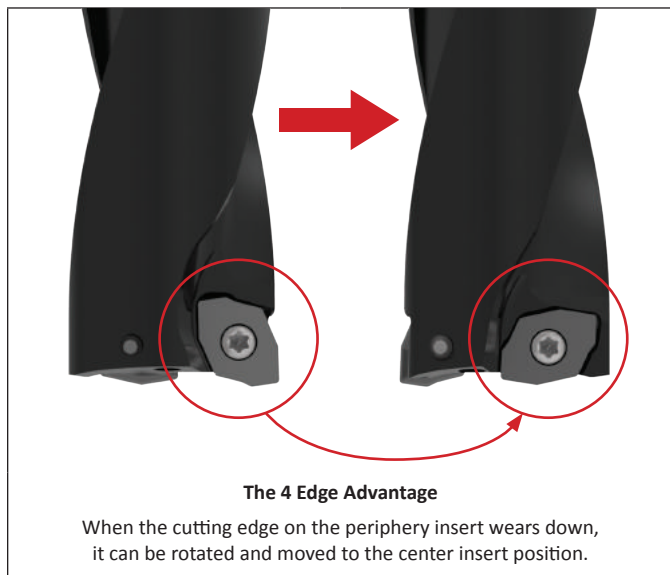

AVAILABLE LENGTHS

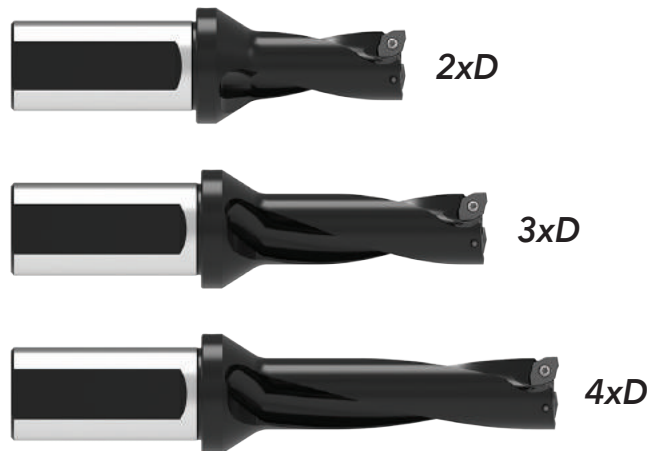

A DRILLING
B BORING
C REAMING
D BURNISHING
E THREADING
X SPECIALS

Insert Information

4 CUTTING EDGES

- Each insert has 2 inner cutting edges and 2 outer cutting edges
- Economical solution that increases tool life because of the rotation ability of the inserts
- Available in ISO material-specific geometry/coating combinations

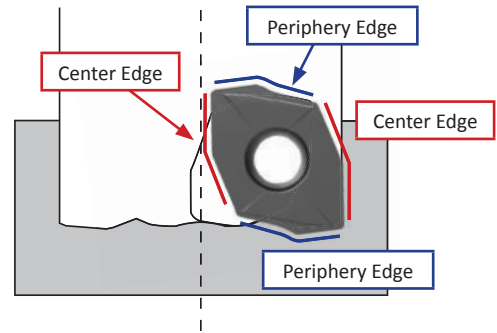

Periphery Insert



Periphery edge chip formation:



Center Insert





Center edge chip formation:



ISO Material	Geometry	Coating	Description
P	General Rake	AM480	A general purpose geometry that provides excellent chip formation in most steels including free machining, medium and high carbon steels. A P30 carbide substrate for improved toughness and AM480 coating, a proprietary wear resistant multi-layer PVD coating to improve tool life.
S M	High Rake	AM485	A higher rake geometry that provides excellent chip formation in both stainless steels and high temperature alloys. A tough M25 carbide substrate coated with AM485, a high heat resistance proprietary multi-layer PVD coating.
K	General Rake	AM480	With a general purpose geometry, the K inserts can be used in grey cast irons as well as ductile irons. A high wear resistant K10 carbide substrate to improve tool life and coated with AM480, a proprietary multi-layer PVD coating to improve resistance against tool wear.
H	Low Rake	AM480	A low rake geometry to improve edge strength in both hardened tool steels and high strength alloys. With a P30 carbide substrate for improved toughness and coated with AM480, a proprietary multi-layer PVD coating to improve resistance against tool wear.
N	High Rake	TiCN	A higher rake cutting geometry provides excellent chip formation in non-ferrous materials. An M15/K15 carbide substrate paired with TiCN coating for improved lubricity to resist build-up-material, increasing tool life and maintaining chip formation.

Insert Information

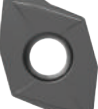
Series	Insert Prefix	Dimension (mm)					Angle		Shape
		L_1	L_2	T	D_1	R	A_1	A_2	
03	4T-030203C-x	5.9	4.8	2.30	2.4	0.3	7°	10°	 Style 1
	4T-030203P-x	6.5	4.8	2.30	2.4	0.3	7°	10°	 Style 2
04	4T-040203-x	6.2	5.1	2.60	2.4	0.3	13°	10°	 Style 3
05	4T-05T203-x	7.3	5.5	2.74	2.5	0.3	13°	7°	
06	4T-06T204-x	8.6	6.4	2.89	2.8	0.4	13°	7°	
07	4T-070305-x	10.2	8.0	3.24	3.0	0.5	13°	7°	
09	4T-09T306-x	12.2	9.6	4.03	3.6	0.6	13°	7°	
11	4T-11T306-x	14.5	11.6	4.06	4.6	0.6	13°	7°	
14	4T-140408-x	18.0	14.4	4.88	5.7	0.8	13°	7°	

Style 1

Style 2

Style 3

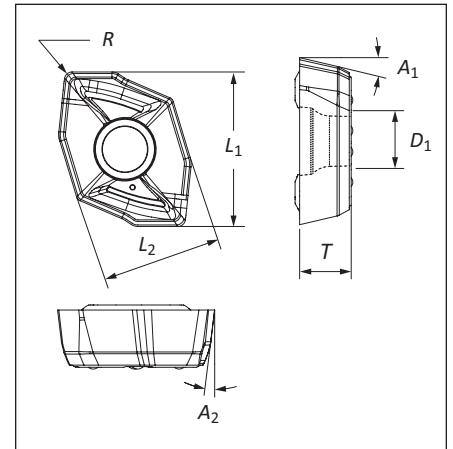
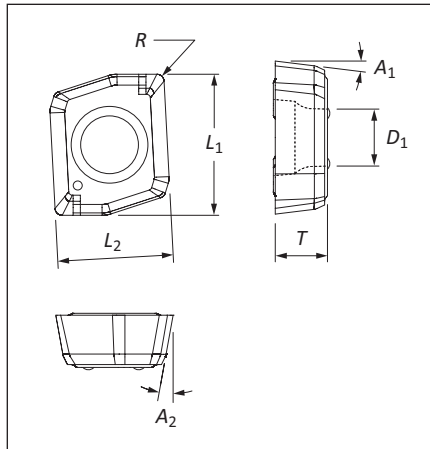
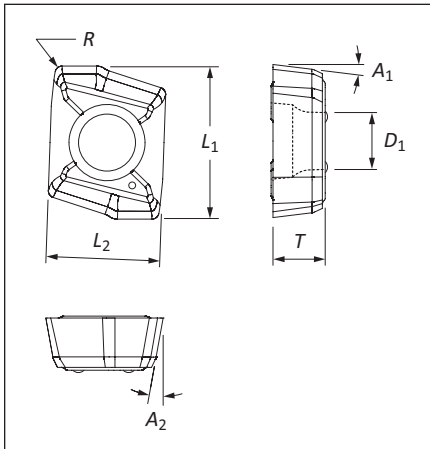

A DRILLING
B BORING
C REAMING
D BURNISHING
E THREADING
X SPECIALS

Product Nomenclature

4TEX Drill Holders

D4	03	1200	M	-	075	F
1	2	3	4		5	6

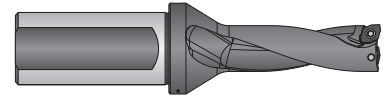

1. Length to Diameter Ratio
D2 = 2xD
D3 = 3xD
D4 = 4xD

2. Series	
03 = 03 series	07 = 07 series
04 = 04 series	09 = 09 series
05 = 05 series	11 = 11 series
06 = 06 series	14 = 14 series

3. Diameter
0750 = .075"
1200 = 12mm

4. Diameter Style
I = Imperial
M = Metric

5. Shank Diameter	
Imperial	Metric
075 = .075"	20 = 20mm
100 = 1.000"	25 = 25mm
125 = 1.250"	32 = 32mm
150 = 1.500"	40 = 40mm

6. Shank Style
F = Imperial flanged shank
FM = Metric flanged shank

Reference Key

Symbol	Attribute
D₁	Drill diameter
D₂	Shank diameter
D₃	Flange diameter
L₁	Assembled overall length
L₂	Drill depth
L₃	Reference length

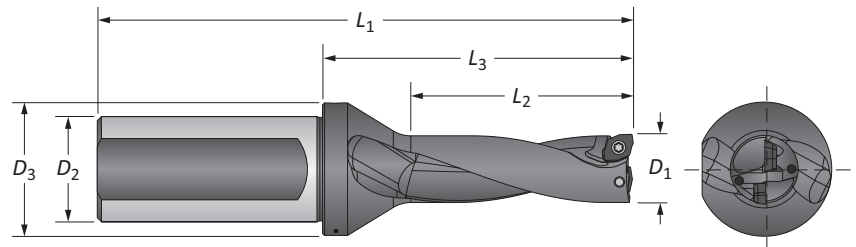

A
DRILLING
B
BORING
C
REAMING
D
BURNISHING
E
THREADING
X
SPECIALS

4TEX Drill Holders | Imperial Shank

03 Series | Diameter Range: 0.472" - 0.531" (12.00mm - 13.49mm)

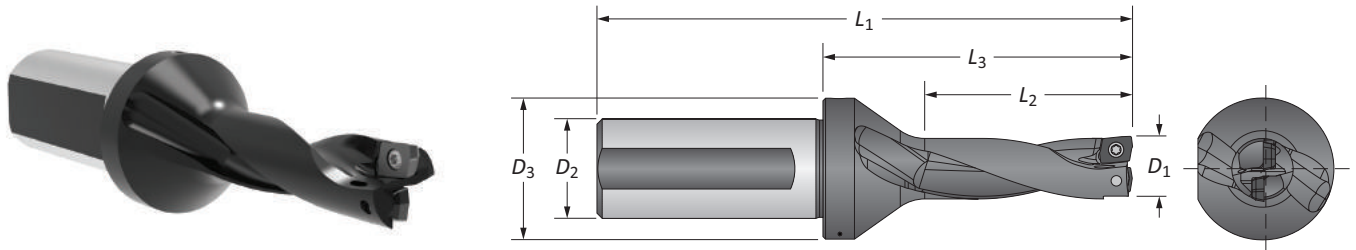

Imperial Shank

Length	Body				Shank		Max Offset	Part No.
	D_1	L_2	L_3	L_1	D_2	D_3		
2xD	12.00mm	0.945	1.787	3.480	0.750	1.063	0.020	D2031200M-075F
	12.50mm	0.984	1.827	3.520	0.750	1.063	0.016	D2031250M-075F
	0.500"	1.000	1.827	3.520	0.750	1.063	0.014	D2030500I-075F
	13.00mm	1.024	1.866	3.559	0.750	1.063	0.012	D2031300M-075F
3xD	12.00mm	1.417	2.260	3.953	0.750	1.063	0.020	D3031200M-075F
	12.50mm	1.476	2.319	4.012	0.750	1.063	0.016	D3031250M-075F
	0.500"	1.500	2.319	4.012	0.750	1.063	0.014	D3030500I-075F
	13.00mm	1.535	2.378	4.071	0.750	1.063	0.012	D3031300M-075F
4xD	12.00mm	1.890	2.732	4.425	0.750	1.063	0.020	D4031200M-075F
	12.50mm	1.969	2.811	4.504	0.750	1.063	0.016	D4031250M-075F
	0.500"	2.000	2.811	4.504	0.750	1.063	0.014	D4030500I-075F
	13.00mm	2.047	2.890	4.583	0.750	1.063	0.012	D4031300M-075F

IC Inserts

ISO Material	Style	Part No.	Insert Screw	Torx® Driver	Admissible Tightening Torque
P	Center	4T-030203C-P	7241-T6-1	8T-6	4.4 in-lbs (0.5 N-cm)
	Periphery	4T-030203P-P			
S M	Center	4T-030203C-M			
	Periphery	4T-030203P-M			
H	Center	4T-030203C-H			
	Periphery	4T-030203P-H			
K	Center	4T-030203C-K			
	Periphery	4T-030203P-K			
N	Center	4T-030203C-N			
	Periphery	4T-030203P-N			

A55: 26 - 27

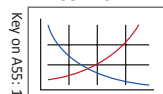

A55: 23 - 25



A55: 22

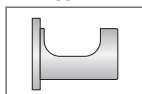

i = Imperial (in)
m = Metric (mm)

IC inserts sold in quantities of 10
 Insert screws sold in quantities of 10



4TEX Drill Holders | Metric Shank

03 Series | Diameter Range: 0.472" - 0.531" (12.00mm - 13.49mm)

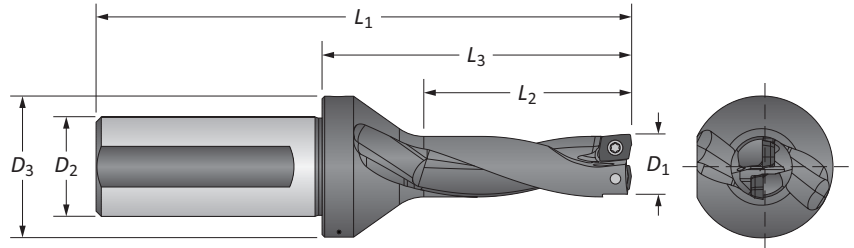

Metric Shank

Length	D ₁	Body			Shank		Max Offset	Part No.
		L ₂	L ₃	L ₁	D ₂	D ₃		
2xD	12.00mm	24.00	45.40	88.40	20.00	27.00	0.50	D2031200M-20FM
	12.50mm	25.00	46.40	89.40	20.00	27.00	0.40	D2031250M-20FM
	0.500"	25.40	46.40	89.40	20.00	27.00	0.35	D2030500I-20FM
	13.00mm	26.00	47.40	90.40	20.00	27.00	0.30	D2031300M-20FM
3xD	12.00mm	36.00	57.40	100.40	20.00	27.00	0.50	D3031200M-20FM
	12.50mm	37.50	58.90	101.90	20.00	27.00	0.40	D3031250M-20FM
	0.500"	38.10	58.90	101.90	20.00	27.00	0.35	D3030500I-20FM
	13.00mm	39.00	60.40	103.40	20.00	27.00	0.30	D3031300M-20FM
4xD	12.00mm	48.00	69.40	112.40	20.00	27.00	0.50	D4031200M-20FM
	12.50mm	50.00	71.40	114.40	20.00	27.00	0.40	D4031250M-20FM
	0.500"	50.80	71.40	114.40	20.00	27.00	0.35	D4030500I-20FM
	13.00mm	52.00	73.40	116.40	20.00	27.00	0.30	D4031300M-20FM

IC Inserts

ISO Material	Style	Part No.	Insert Screw	Torx® Driver	Admissible Tightening Torque
P	Center	4T-030203C-P	7241-T6-1	8T-6	4.4 in-lbs (0.5 N-cm)
	Periphery	4T-030203P-P			
S M	Center	4T-030203C-M			
	Periphery	4T-030203P-M			
H	Center	4T-030203C-H			
	Periphery	4T-030203P-H			
K	Center	4T-030203C-K			
	Periphery	4T-030203P-K			
N	Center	4T-030203C-N			
	Periphery	4T-030203P-N			

Key on A55: 1

A55: 26 - 27

A55: 23 - 25

A55: 22

i = Imperial (in)
m = Metric (mm)
 IC inserts sold in quantities of 10
 Insert screws sold in quantities of 10

A DRILLING
 B BORING
 C REAMING
 D BURNISHING
 E THREADING
 X SPECIALS

4TEX Drill Holders | Imperial Shank

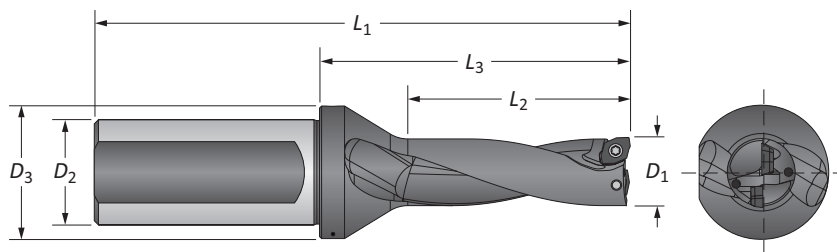

04 Series | Diameter Range: 0.532" - 0.610" (13.50mm - 15.49mm)



Imperial Shank

Length	D_1	Body			Shank		Max Offset	Part No.
		L_2	L_3	L_1	D_2	D_3		
2xD	13.50mm	1.063	1.906	3.598	0.750	1.063	0.020	D2041350M-075F
	14.00mm	1.102	1.945	3.638	0.750	1.063	0.016	D2041400M-075F
	0.562"	1.124	1.945	3.638	0.750	1.063	0.013	D2040562I-075F
	14.50mm	1.142	1.984	3.677	0.750	1.063	0.012	D2041450M-075F
	15.00mm	1.181	2.024	3.717	0.750	1.063	0.008	D2041500M-075F
3xD	13.50mm	1.594	2.437	4.130	0.750	1.063	0.020	D3041350M-075F
	14.00mm	1.654	2.496	4.189	0.750	1.063	0.016	D3041400M-075F
	0.562"	1.686	2.496	4.189	0.750	1.063	0.013	D3040562I-075F
	14.50mm	1.713	2.555	4.248	0.750	1.063	0.012	D3041450M-075F
	15.00mm	1.772	2.614	4.307	0.750	1.063	0.008	D3041500M-075F
4xD	13.50mm	2.126	2.969	4.661	0.750	1.063	0.020	D4041350M-075F
	14.00mm	2.205	3.047	4.740	0.750	1.063	0.016	D4041400M-075F
	0.562"	2.248	3.047	4.740	0.750	1.063	0.013	D4040562I-075F
	14.50mm	2.283	3.126	4.819	0.750	1.063	0.012	D4041450M-075F
	15.00mm	2.362	3.205	4.898	0.750	1.063	0.008	D4041500M-075F

IC Inserts

ISO Material	Part No.	 Insert Screw	 Torx® Driver	Admissible Tightening Torque
P	4T-040203-P	7241-T6-1	8T-6	4.4 in-lbs (0.5 N-cm)
S M	4T-040203-M			
H	4T-040203-H			
K	4T-040203-K			
N	4T-040203-N			

A55: 26 - 27

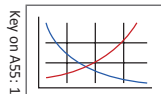

A55: 23 - 25



A55: 22

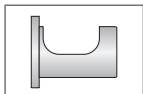

i = Imperial (in)
m = Metric (mm)

IC inserts sold in quantities of 10
Insert screws sold in quantities of 10



4TEX Drill Holders | Metric Shank

04 Series | Diameter Range: 0.532" - 0.610" (13.50mm - 15.49mm)

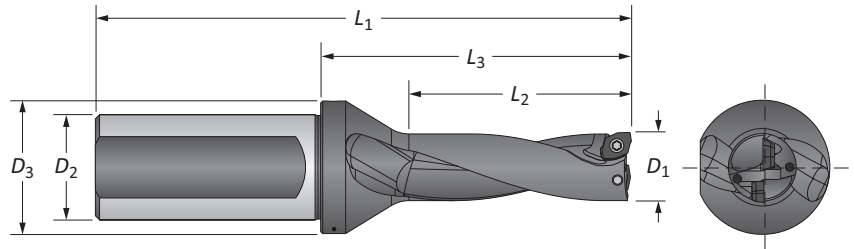

Metric Shank

Length	D ₁	Body			Shank		Max Offset	Part No.
		L ₂	L ₃	L ₁	D ₂	D ₃		
2xD	13.50mm	27.00	48.40	91.40	20.00	27.00	0.50	D2041350M-20FM
	14.00mm	28.00	49.40	92.40	20.00	27.00	0.40	D2041400M-20FM
	0.562"	28.55	49.40	92.40	20.00	27.00	0.30	D2040562I-20FM
	14.50mm	29.00	50.40	93.40	20.00	27.00	0.30	D2041450M-20FM
3xD	13.50mm	40.50	61.90	104.90	20.00	27.00	0.50	D3041350M-20FM
	14.00mm	42.00	63.40	106.40	20.00	27.00	0.40	D3041400M-20FM
	0.562"	42.82	63.40	106.40	20.00	27.00	0.30	D3040562I-20FM
	14.50mm	43.50	64.90	107.90	20.00	27.00	0.30	D3041450M-20FM
4xD	13.50mm	54.00	75.40	118.40	20.00	27.00	0.50	D3041350M-20FM
	14.00mm	56.00	77.40	120.40	20.00	27.00	0.40	D4041400M-20FM
	0.562"	57.10	77.40	120.40	20.00	27.00	0.30	D4040562I-20FM
	14.50mm	58.00	79.40	122.40	20.00	27.00	0.30	D4041450M-20FM
	15.00mm	60.00	81.40	124.40	20.00	27.00	0.20	D4041500M-20FM

IC Inserts

ISO Material	Part No.	Insert Screw	Torx® Driver	Admissible Tightening Torque
P	4T-040203-P	7241-T6-1	8T-6	4.4 in-lbs (0.5 N-cm)
S M	4T-040203-M			
H	4T-040203-H			
K	4T-040203-K			
N	4T-040203-N			

Key on ASS: 1

A55: 26 - 27

A55: 23 - 25

A55: 22

ⓘ = Imperial (in)
 ⓘ = Metric (mm)

IC inserts sold in quantities of 10
 Insert screws sold in quantities of 10

A
DRILLING
B
BORING
C
REAMING
D
BURNISHING
E
THREADING
X
SPECIALS

4TEX Drill Holders | Imperial Shank

05 Series | Diameter Range: 0.611" - 0.728" (15.50mm - 18.49mm)

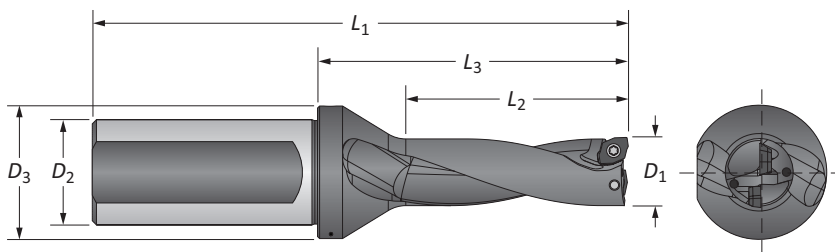

Imperial Shank

Length	Body				Shank		Max Offset	Part No.
	D_1	L_2	L_3	L_1	D_2	D_3		
2xD	15.50mm	1.220	2.146	4.272	1.000	1.260	0.031	D2051550M-100F
	0.625"	1.250	2.146	4.272	1.000	1.260	0.029	D2050625I-100F
	16.00mm	1.260	2.185	4.311	1.000	1.260	0.028	D2051600M-100F
	16.50mm	1.299	2.224	4.350	1.000	1.260	0.020	D2051650M-100F
	17.00mm	1.339	2.264	4.390	1.000	1.260	0.016	D2051700M-100F
	0.687"	1.374	2.264	4.390	1.000	1.260	0.012	D2050687I-100F
	17.50mm	1.378	2.303	4.429	1.000	1.260	0.012	D2051750M-100F
3xD	18.00mm	1.417	2.343	4.469	1.000	1.260	0.008	D2051800M-100F
	15.50mm	1.831	2.756	4.882	1.000	1.260	0.031	D3051550M-100F
	0.625"	1.875	2.756	4.882	1.000	1.260	0.029	D3050625I-100F
	16.00mm	1.890	2.815	4.941	1.000	1.260	0.028	D3051600M-100F
	16.50mm	1.949	2.874	5.000	1.000	1.260	0.020	D3051650M-100F
	17.00mm	2.008	2.933	5.059	1.000	1.260	0.016	D3051700M-100F
	0.687"	2.061	2.933	5.059	1.000	1.260	0.012	D3050687I-100F
4xD	17.50mm	2.067	2.992	5.118	1.000	1.260	0.012	D3051750M-100F
	18.00mm	2.126	3.051	5.177	1.000	1.260	0.008	D3051800M-100F
	15.50mm	2.441	3.366	5.492	1.000	1.260	0.031	D4051550M-100F
	0.625"	2.500	3.366	5.492	1.000	1.260	0.029	D4050625I-100F
	16.00mm	2.520	3.445	5.571	1.000	1.260	0.028	D4051600M-100F
	16.50mm	2.598	3.524	5.650	1.000	1.260	0.020	D4051650M-100F
	17.00mm	2.677	3.602	5.728	1.000	1.260	0.016	D4051700M-100F
0.687"	2.748	3.602	5.728	1.000	1.260	0.012	D4050687I-100F	
17.50mm	2.756	3.681	5.807	1.000	1.260	0.012	D4051750M-100F	
18.00mm	2.835	3.760	5.886	1.000	1.260	0.008	D4051800M-100F	

IC Inserts

ISO Material	Part No.	Insert Screw	Torx® Driver	Admissible Tightening Torque
P	4T-05T203-P	7243-T6-1	8T-6	4.4 in-lbs (0.5 N-cm)
S M	4T-05T203-M			
H	4T-05T203-H			
K	4T-05T203-K			
N	4T-05T203-N			

A55: 26 - 27

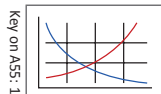

A55: 23 - 25



A55: 22

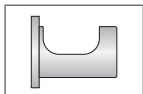

ⓘ = Imperial (in)
 ⓘ = Metric (mm)

IC inserts sold in quantities of 10
 Insert screws sold in quantities of 10



4TEX Drill Holders | Metric Shank

05 Series | Diameter Range: 0.611" - 0.728" (15.50mm - 18.49mm)

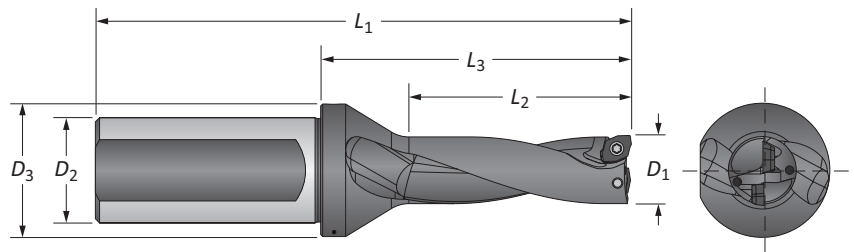

Metric Shank

Length	Body				Shank		Max Offset	Part No.
	D ₁	L ₂	L ₃	L ₁	D ₂	D ₃		
2xD	15.50mm	31.00	54.50	108.50	25.00	32.00	0.80	D2051550M-25FM
	0.625"	31.75	54.50	108.50	25.00	32.00	0.70	D2050625I-25FM
	16.00mm	32.00	55.50	109.50	25.00	32.00	0.70	D2051600M-25FM
	16.50mm	33.00	56.50	110.50	25.00	32.00	0.50	D2051650M-25FM
	17.00mm	34.00	57.50	111.50	25.00	32.00	0.40	D2051700M-25FM
	0.687"	34.90	57.50	111.50	25.00	32.00	0.30	D2050687I-25FM
	17.50mm	35.00	58.50	112.50	25.00	32.00	0.30	D2051750M-25FM
3xD	18.00mm	36.00	59.50	113.50	25.00	32.00	0.20	D2051800M-25FM
	15.50mm	46.50	70.00	124.00	25.00	32.00	0.80	D3051550M-25FM
	0.625"	47.63	70.00	124.00	25.00	32.00	0.70	D3050625I-25FM
	16.00mm	48.00	71.50	125.50	25.00	32.00	0.70	D3051600M-25FM
	16.50mm	49.50	73.00	127.00	25.00	32.00	0.50	D3051650M-25FM
	17.00mm	51.00	74.50	128.50	25.00	32.00	0.40	D3051700M-25FM
	0.687"	52.35	74.50	128.50	25.00	32.00	0.30	D3050687I-25FM
4xD	17.50mm	52.50	76.00	130.00	25.00	32.00	0.30	D3051750M-25FM
	18.00mm	54.00	77.50	131.50	25.00	32.00	0.20	D3051800M-25FM
	15.50mm	62.00	85.50	139.50	25.00	32.00	0.80	D4051550M-25FM
	0.625"	63.50	85.50	139.50	25.00	32.00	0.70	D4050625I-25FM
	16.00mm	64.00	87.50	141.50	25.00	32.00	0.70	D4051600M-25FM
	16.50mm	66.00	89.50	143.50	25.00	32.00	0.50	D4051650M-25FM
	17.00mm	68.00	91.50	145.50	25.00	32.00	0.40	D4051700M-25FM
4xD	0.687"	69.80	91.50	145.50	25.00	32.00	0.30	D4050687I-25FM
	17.50mm	70.00	93.50	147.50	25.00	32.00	0.30	D4051750M-25FM
	18.00mm	72.00	95.50	149.50	25.00	32.00	0.20	D4051800M-25FM

IC Inserts

ISO Material	Part No.	Insert Screw	Torx® Driver	Admissible Tightening Torque
P	4T-05T203-P	7243-T6-1	8T-6	4.4 in-lbs (0.5 N-cm)
S M	4T-05T203-M			
H	4T-05T203-H			
K	4T-05T203-K			
N	4T-05T203-N			

Key on ASS: 1

A55: 26 - 27

A55: 23 - 25

A55: 22

ⓘ = Imperial (in)
 ⓘ = Metric (mm)

IC inserts sold in quantities of 10
 Insert screws sold in quantities of 10

A DRILLING
B BORING
C REAMING
D BURNISHING
E THREADING
X SPECIALS

4TEX Drill Holders | Imperial Shank

06 Series | Diameter Range: 0.729" - 0.866" (18.50mm - 21.99mm)

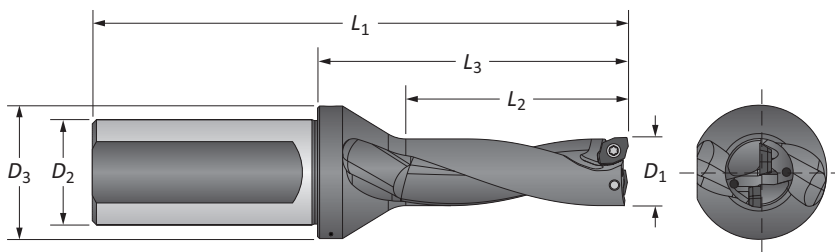

Imperial Shank

Length	Body				Shank		Max Offset	Part No.
	D_1	L_2	L_3	L_1	D_2	D_3		
2xD	18.50mm	1.457	2.299	4.425	1.000	1.260	0.035	D2061850M-100F
	19.00mm	1.496	2.339	4.465	1.000	1.260	0.031	D2061900M-100F
	0.750"	1.500	2.339	4.465	1.000	1.260	0.031	D2060750I-100F
	19.50mm	1.535	2.378	4.504	1.000	1.260	0.028	D2061950M-100F
	20.00mm	1.575	2.417	4.543	1.000	1.260	0.020	D2062000M-100F
	20.50mm	1.614	2.457	4.583	1.000	1.260	0.016	D2062050M-100F
	0.812"	1.624	2.457	4.583	1.000	1.260	0.015	D2060812I-100F
	21.00mm	1.654	2.496	4.622	1.000	1.260	0.012	D2062100M-100F
3xD	21.50mm	1.693	2.535	4.661	1.000	1.260	0.008	D2062150M-100F
	18.50mm	2.165	3.028	5.154	1.000	1.260	0.035	D3061850M-100F
	19.00mm	2.244	3.087	5.213	1.000	1.260	0.031	D3061900M-100F
	0.750"	2.250	3.087	5.213	1.000	1.260	0.031	D3060750I-100F
	19.50mm	2.303	3.146	5.272	1.000	1.260	0.028	D3061950M-100F
	20.00mm	2.362	3.205	5.331	1.000	1.260	0.020	D3062000M-100F
	20.50mm	2.421	3.264	5.390	1.000	1.260	0.016	D3062050M-100F
	0.812"	2.436	3.264	5.390	1.000	1.260	0.015	D3060812I-100F
4xD	21.00mm	2.480	3.323	5.449	1.000	1.260	0.012	D3062100M-100F
	21.50mm	2.539	3.382	5.508	1.000	1.260	0.008	D3062150M-100F
	18.50mm	2.913	3.756	5.882	1.000	1.260	0.035	D4061850M-100F
	19.00mm	2.992	3.835	5.961	1.000	1.260	0.031	D4061900M-100F
	0.750"	3.000	3.835	5.961	1.000	1.260	0.031	D4060750I-100F
	19.50mm	3.071	3.913	6.039	1.000	1.260	0.028	D4061950M-100F
	20.00mm	3.150	3.992	6.118	1.000	1.260	0.020	D4062000M-100F
	20.50mm	3.228	4.071	6.197	1.000	1.260	0.016	D4062050M-100F
5xD	0.812"	3.248	4.071	6.197	1.000	1.260	0.015	D4060812I-100F
	21.00mm	3.307	4.150	6.276	1.000	1.260	0.012	D4062100M-100F
	21.50mm	3.386	4.228	6.354	1.000	1.260	0.008	D4062150M-100F

IC Inserts

ISO Material	Part No.	Insert Screw	Torx® Driver	Admissible Tightening Torque
P	4T-06T204-P	72251-T7-1	8T-7	7.1 in-lbs (0.8 N-cm)
S M	4T-06T204-M			
H	4T-06T204-H			
K	4T-06T204-K			
N	4T-06T204-N			

A55: 26 - 27

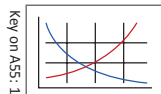

A55: 23 - 25



A55: 22

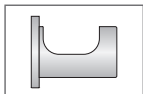

i = Imperial (in)

m = Metric (mm)

IC inserts sold in quantities of 10
Insert screws sold in quantities of 10



4TEX Drill Holders | Metric Shank

06 Series | Diameter Range: 0.729" - 0.866" (18.50mm - 21.99mm)

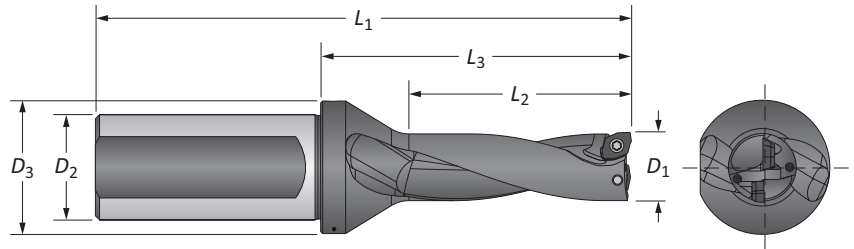

Metric Shank

Length	Body				Shank		Max Offset	Part No.
	D ₁	L ₂	L ₃	L ₁	D ₂	D ₃		
2xD	18.50mm	37.00	58.40	112.40	25.00	32.00	0.90	D2061850M-25FM
	19.00mm	38.00	59.40	113.40	25.00	32.00	0.80	D2061900M-25FM
	0.750"	38.10	59.40	113.40	25.00	32.00	0.80	D2060750I-25FM
	19.50mm	39.00	60.40	114.40	25.00	32.00	0.70	D2061950M-25FM
	20.00mm	40.00	61.40	115.40	25.00	32.00	0.50	D2062000M-25FM
	20.50mm	41.00	62.40	116.40	25.00	32.00	0.40	D2062050M-25FM
	0.812"	41.25	62.40	116.40	25.00	32.00	0.40	D2060812I-25FM
	21.00mm	42.00	63.40	117.40	25.00	32.00	0.30	D2062100M-25FM
3xD	21.50mm	43.00	64.40	118.40	25.00	32.00	0.20	D2062150M-25FM
	18.50mm	55.00	76.90	130.90	25.00	32.00	0.90	D3061850M-25FM
	19.00mm	57.00	78.40	132.40	25.00	32.00	0.80	D3061900M-25FM
	0.750"	57.15	78.40	132.40	25.00	32.00	0.80	D3060750I-25FM
	19.50mm	58.50	79.90	133.90	25.00	32.00	0.70	D3061950M-25FM
	20.00mm	60.00	81.40	135.40	25.00	32.00	0.50	D3062000M-25FM
	20.50mm	61.50	82.90	136.90	25.00	32.00	0.40	D3062050M-25FM
	0.812"	61.87	82.90	136.90	25.00	32.00	0.40	D3060812I-25FM
4xD	21.00mm	63.00	84.40	138.40	25.00	32.00	0.30	D3062100M-25FM
	21.50mm	64.50	85.90	139.90	25.00	32.00	0.20	D3062150M-25FM
	18.50mm	74.00	95.40	149.40	25.00	32.00	0.90	D4061850M-25FM
	19.00mm	76.00	97.40	151.40	25.00	32.00	0.80	D4061900M-25FM
	0.750"	76.20	97.40	151.40	25.00	32.00	0.80	D4060750I-25FM
	19.50mm	78.00	99.40	153.40	25.00	32.00	0.70	D4061950M-25FM
	20.00mm	80.00	101.40	155.40	25.00	32.00	0.50	D4062000M-25FM
	20.50mm	82.00	103.40	157.40	25.00	32.00	0.40	D4062050M-25FM
4xD	0.812"	82.49	103.40	157.40	25.00	32.00	0.40	D4060812I-25FM
	21.00mm	84.00	105.40	159.40	25.00	32.00	0.30	D4062100M-25FM
	21.50mm	86.00	107.40	161.40	25.00	32.00	0.20	D4062150M-25FM

IC Inserts

ISO Material	Part No.	Insert Screw	Torx® Driver	Admissible Tightening Torque
P	4T-06T204-P	72251-T7-1	8T-7	7.1 in-lbs (0.8 N-cm)
S M	4T-06T204-M			
H	4T-06T204-H			
K	4T-06T204-K			
N	4T-06T204-N			

Key on ASS: 1

A55: 26 - 27

A55: 23 - 25

A55: 22

ⓘ = Imperial (in)
 ⓘ = Metric (mm)

IC inserts sold in quantities of 10
 Insert screws sold in quantities of 10

4TEX Drill Holders | Imperial Shank

07 Series | Diameter Range: 0.867" - 1.043" (22.00mm - 26.49mm)

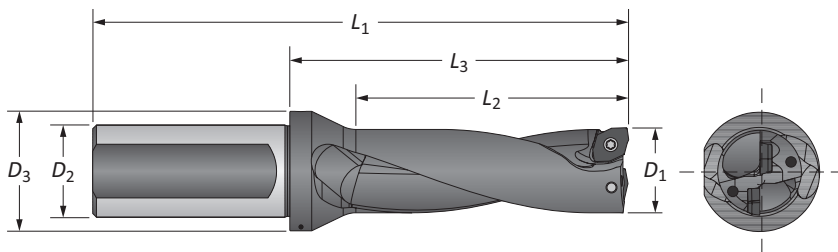

Imperial Shank

Length	Body				Shank		Max Offset	Part No.
	D ₁	L ₂	L ₃	L ₁	D ₂	D ₃		
2xD	22.00mm	1.732	2.555	4.681	1.000	1.299	0.047	D2072200M-100F
	0.875"	1.750	2.555	4.681	1.000	1.299	0.043	D2070875I-100F
	22.50mm	1.772	2.594	4.720	1.000	1.299	0.039	D2072250M-100F
	23.00mm	1.811	2.634	4.760	1.000	1.299	0.035	D2072300M-100F
	23.50mm	1.850	2.673	4.799	1.000	1.299	0.031	D2072350M-100F
	0.937"	1.874	2.673	4.799	1.000	1.299	0.292	D2070937I-100F
	24.00mm	1.890	2.713	4.839	1.000	1.299	0.028	D2072400M-100F
	24.50mm	1.929	2.752	4.878	1.000	1.299	0.020	D2072450M-100F
	25.00mm	1.969	2.791	4.917	1.000	1.299	0.016	D2072500M-100F
	1.000"	2.000	2.791	4.917	1.000	1.299	0.013	D2071000I-100F
3xD	22.00mm	2.598	3.421	5.547	1.000	1.299	0.047	D3072200M-100F
	0.875"	2.625	3.421	5.547	1.000	1.299	0.043	D3070875I-100F
	22.50mm	2.657	3.480	5.606	1.000	1.299	0.039	D3072250M-100F
	23.00mm	2.717	3.539	5.665	1.000	1.299	0.035	D3072300M-100F
	23.50mm	2.776	3.598	5.724	1.000	1.299	0.031	D3072350M-100F
	0.937"	2.811	3.598	5.724	1.000	1.299	0.292	D3070937I-100F
	24.00mm	2.835	3.657	5.783	1.000	1.299	0.028	D3072400M-100F
	24.50mm	2.894	3.717	5.843	1.000	1.299	0.020	D3072450M-100F
	25.00mm	2.953	3.776	5.902	1.000	1.299	0.016	D3072500M-100F
	1.000"	3.000	3.776	5.902	1.000	1.299	0.013	D3071000I-100F
4xD	22.00mm	3.465	4.287	6.413	1.000	1.299	0.047	D4072200M-100F
	0.875"	3.500	4.287	6.413	1.000	1.299	0.043	D4070875I-100F
	22.50mm	3.543	4.366	6.492	1.000	1.299	0.039	D4072250M-100F
	23.00mm	3.622	4.445	6.571	1.000	1.299	0.035	D4072300M-100F
	23.50mm	3.701	4.524	6.650	1.000	1.299	0.031	D4072350M-100F
	0.937"	3.748	4.524	6.650	1.000	1.299	0.292	D4070937I-100F
	24.00mm	3.780	4.602	6.728	1.000	1.299	0.028	D4072400M-100F
	24.50mm	3.858	4.681	6.807	1.000	1.299	0.020	D4072450M-100F
	25.00mm	3.937	4.760	6.886	1.000	1.299	0.016	D4072500M-100F
	1.000"	4.000	4.760	6.886	1.000	1.299	0.013	D4071000I-100F
25.50mm	4.016	4.839	6.965	1.000	1.299	0.012	D4072550M-100F	
26.00mm	4.094	4.917	7.043	1.000	1.299	0.008	D4072600M-100F	

IC Inserts

ISO Material	Part No.	Insert Screw	Torx® Driver	Admissible Tightening Torque
P	4T-070305-P	72568-T8-1	8T-8	10.6 in-lbs (1.2 N-cm)
S M	4T-070305-M			
H	4T-070305-H			
K	4T-070305-K			
N	4T-070305-N			

A55: 26 - 27

A55: 23 - 25

A55: 22

ⓘ = Imperial (in)
 ⓘ = Metric (mm)

IC inserts sold in quantities of 10
 Insert screws sold in quantities of 10



4TEX Drill Holders | Metric Shank

07 Series | Diameter Range: 0.867" - 1.043" (22.00mm - 26.49mm)

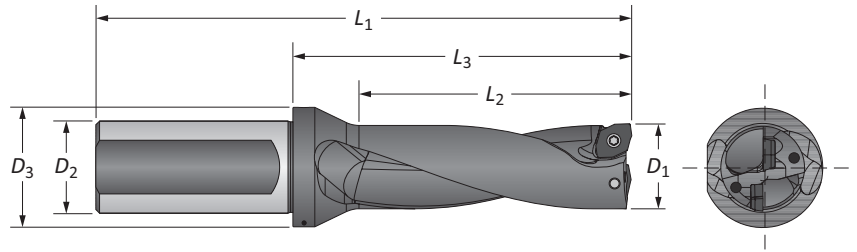

Metric Shank

Length	Body				Shank		Max Offset	Part No.
	D ₁	L ₂	L ₃	L ₁	D ₂	D ₃		
2xD	22.00mm	44.00	64.90	118.90	25.00	33.00	1.20	D2072200M-25FM
	0.875"	44.45	64.90	118.90	25.00	33.00	1.10	D2070875I-25FM
	22.50mm	45.00	65.90	119.90	25.00	33.00	1.00	D2072250M-25FM
	23.00mm	46.00	66.90	120.90	25.00	33.00	0.90	D2072300M-25FM
	23.50mm	47.00	67.90	121.90	25.00	33.00	0.80	D2072350M-25FM
	0.937"	47.60	67.90	121.90	25.00	33.00	7.40	D2070937I-25FM
	24.00mm	48.00	68.90	122.90	25.00	33.00	0.70	D2072400M-25FM
	24.50mm	49.00	69.90	123.90	25.00	33.00	0.50	D2072450M-25FM
	25.00mm	50.00	70.90	124.90	25.00	33.00	0.40	D2072500M-25FM
	1.000"	50.80	70.90	124.90	25.00	33.00	0.30	D2071000I-25FM
3xD	25.50mm	51.00	71.90	125.90	25.00	33.00	0.30	D2072550M-25FM
	26.00mm	52.00	72.90	126.90	25.00	33.00	0.20	D2072600M-25FM
	22.00mm	66.00	86.90	140.90	25.00	33.00	1.20	D3072200M-25FM
	0.875"	66.68	86.90	140.90	25.00	33.00	1.10	D3070875I-25FM
	22.50mm	67.50	88.40	142.40	25.00	33.00	1.00	D3072250M-25FM
	23.00mm	69.00	89.90	143.90	25.00	33.00	0.90	D3072300M-25FM
	23.50mm	70.50	91.40	145.40	25.00	33.00	0.80	D3072350M-25FM
	0.937"	71.40	91.40	145.40	25.00	33.00	7.40	D3070937I-25FM
	24.00mm	72.00	92.90	146.90	25.00	33.00	0.70	D3072400M-25FM
	24.50mm	73.50	94.40	148.40	25.00	33.00	0.50	D3072450M-25FM
4xD	25.00mm	75.00	95.90	149.90	25.00	33.00	0.40	D3072500M-25FM
	1.000"	76.20	95.90	149.90	25.00	33.00	0.30	D3071000I-25FM
	25.50mm	76.50	97.00	151.00	25.00	33.00	0.30	D3072550M-25FM
	26.00mm	78.00	99.00	153.00	25.00	33.00	0.20	D3072600M-25FM
	22.00mm	88.00	109.00	163.00	25.00	33.00	1.20	D4072200M-25FM
	0.875"	88.90	108.90	162.90	25.00	33.00	1.10	D4070875I-25FM
	22.50mm	90.00	111.00	165.00	25.00	33.00	1.00	D4072250M-25FM
	23.00mm	92.00	113.00	167.00	25.00	33.00	0.90	D4072300M-25FM
	23.50mm	94.00	115.00	169.00	25.00	33.00	0.80	D4072350M-25FM
	0.937"	95.20	114.90	168.90	25.00	33.00	7.40	D4070937I-25FM
	24.00mm	96.00	117.00	171.00	25.00	33.00	0.70	D4072400M-25FM
	24.50mm	98.00	119.00	173.00	25.00	33.00	0.50	D4072450M-25FM
	25.00mm	100.00	121.00	175.00	25.00	33.00	0.40	D4072500M-25FM
	1.000"	101.60	120.90	174.90	25.00	33.00	0.30	D4071000I-25FM
	25.50mm	102.00	123.00	177.00	25.00	33.00	0.30	D4072550M-25FM
	26.00mm	104.00	125.00	179.00	25.00	33.00	0.20	D4072600M-25FM

IC Inserts

ISO Material	Part No.	Insert Screw	Torx® Driver	Admissible Tightening Torque
P	4T-070305-P	72568-T8-1	8T-8	10.6 in-lbs (1.2 N-cm)
S M	4T-070305-M			
H	4T-070305-H			
K	4T-070305-K			
N	4T-070305-N			

A55: 26 - 27 A55: 23 - 25 A55: 22

Key on A55: 1

ⓘ = Imperial (in)
 ⓘ = Metric (mm)
 IC inserts sold in quantities of 10
 Insert screws sold in quantities of 10

A
 DRILLING
 B
 BORING
 C
 REAMING
 D
 BURNISHING
 E
 THREADING
 X
 SPECIALS

4TEX Drill Holders | Imperial Shank

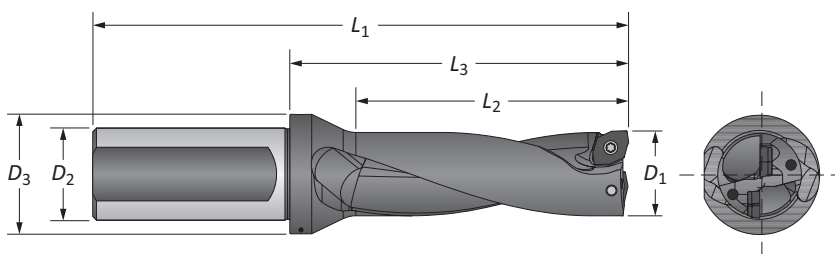

09 Series | Diameter Range: 1.044" - 1.259" (26.50mm - 31.99mm)



Imperial Shank

Length	Body				Shank		Max Offset	Part No.
	D_1	L_2	L_3	L_1	D_2	D_3		
2xD	27.00mm	2.126	3.020	5.343	1.250	1.614	0.063	D2092700M-125F
	28.00mm	2.205	3.098	5.421	1.250	1.614	0.051	D2092800M-125F
	1.125"	2.250	3.138	5.461	1.250	1.614	0.046	D2091125I-125F
	29.00mm	2.283	3.177	5.500	1.250	1.614	0.043	D2092900M-125F
	30.00mm	2.362	3.256	5.579	1.250	1.693	0.031	D2093000M-125F
	31.00mm	2.441	3.335	5.657	1.250	1.693	0.024	D2093100M-125F
	1.250"	2.500	3.374	5.697	1.250	1.693	0.019	D2091250I-125F
3xD	27.00mm	3.189	4.083	6.406	1.250	1.614	0.063	D3092700M-125F
	28.00mm	3.307	4.201	6.524	1.250	1.614	0.051	D3092800M-125F
	1.125"	3.375	4.260	6.583	1.250	1.614	0.046	D3091125I-125F
	29.00mm	3.425	4.319	6.642	1.250	1.614	0.043	D3092900M-125F
	30.00mm	3.543	4.437	6.760	1.250	1.693	0.031	D3093000M-125F
	31.00mm	3.661	4.555	6.878	1.250	1.693	0.024	D3093100M-125F
	1.250"	3.750	4.614	6.937	1.250	1.693	0.019	D3091250I-125F
4xD	27.00mm	4.252	5.146	7.469	1.250	1.614	0.063	D4092700M-125F
	28.00mm	4.409	5.303	7.626	1.250	1.614	0.051	D4092800M-125F
	1.125"	4.500	5.382	7.705	1.250	1.614	0.046	D4091125I-125F
	29.00mm	4.567	5.461	7.783	1.250	1.614	0.043	D4092900M-125F
	30.00mm	4.724	5.618	7.941	1.250	1.693	0.031	D4093000M-125F
	31.00mm	4.882	5.776	8.098	1.250	1.693	0.024	D4093100M-125F
	1.250"	5.000	5.854	8.177	1.250	1.693	0.019	D4091250I-125F

IC Inserts

ISO Material	Part No.	 Insert Screw	 Torx® Driver	Admissible Tightening Torque
P	4T-09T306-P	738-T10-1	8T-10	17.7 in-lbs (2.0 N-cm)
S M	4T-09T306-M			
H	4T-09T306-H			
K	4T-09T306-K			
N	4T-09T306-N			

A55: 26 - 27

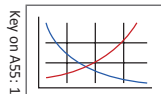

A55: 23 - 25



A55: 22

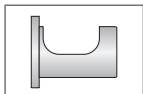

i = Imperial (in)
m = Metric (mm)

IC inserts sold in quantities of 10
Insert screws sold in quantities of 10



4TEX Drill Holders | Metric Shank

09 Series | Diameter Range: 1.044" - 1.259" (26.50mm - 31.99mm)

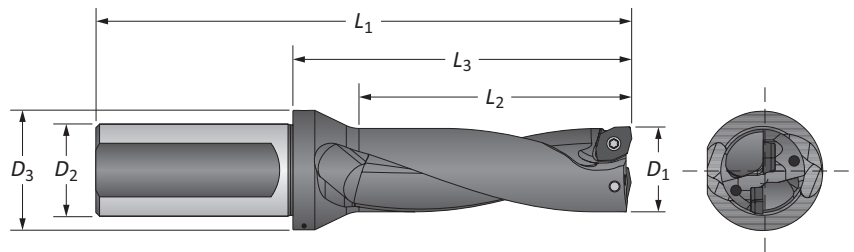

Metric Shank

Length	Body				Shank		Max Offset	Part No.
	D ₁	L ₂	L ₃	L ₁	D ₂	D ₃		
2xD	27.00mm	54.00	76.70	135.70	32.00	41.00	1.60	D2092700M-32FM
	28.00mm	56.00	78.70	137.70	32.00	41.00	1.30	D2092800M-32FM
	1.125"	57.15	79.70	138.70	32.00	41.00	1.20	D2091125I-32FM
	29.00mm	58.00	80.70	139.70	32.00	41.00	1.10	D2092900M-32FM
	30.00mm	60.00	82.70	141.70	32.00	43.00	0.80	D2093000M-32FM
	31.00mm	62.00	84.70	143.70	32.00	43.00	0.60	D2093100M-32FM
3xD	1.250"	63.50	85.70	144.70	32.00	43.00	0.50	D2091250I-32FM
	27.00mm	81.00	103.70	162.70	32.00	41.00	1.60	D3092700M-32FM
	28.00mm	84.00	106.70	165.70	32.00	41.00	1.30	D3092800M-32FM
	1.125"	85.73	108.20	167.20	32.00	41.00	1.20	D3091125I-32FM
	29.00mm	87.00	109.70	168.70	32.00	41.00	1.10	D3092900M-32FM
	30.00mm	90.00	112.70	171.70	32.00	43.00	0.80	D3093000M-32FM
4xD	31.00mm	93.00	115.70	174.70	32.00	43.00	0.60	D3093100M-32FM
	1.250"	95.25	117.20	176.20	32.00	43.00	0.50	D3091250I-32FM
	27.00mm	108.00	130.70	189.70	32.00	41.00	1.60	D4092700M-32FM
	28.00mm	112.00	134.70	193.70	32.00	41.00	1.30	D4092800M-32FM
	1.125"	114.30	136.70	195.70	32.00	41.00	1.20	D4091125I-32FM
	29.00mm	116.00	138.70	197.70	32.00	41.00	1.10	D4092900M-32FM
4xD	30.00mm	120.00	142.70	201.70	32.00	43.00	0.80	D4093000M-32FM
	31.00mm	124.00	146.70	205.70	32.00	43.00	0.60	D4093100M-32FM
	1.250"	127.00	148.70	207.70	32.00	43.00	0.50	D4091250I-32FM

IC Inserts

ISO Material	Part No.	Insert Screw	Torx® Driver	Admissible Tightening Torque
P	4T-09T306-P	738-T10-1	8T-10	17.7 in-lbs (2.0 N-cm)
S M	4T-09T306-M			
H	4T-09T306-H			
K	4T-09T306-K			
N	4T-09T306-N			

Key on ASS-1

A55: 26 - 27

A55: 23 - 25

A55: 22

ⓘ = Imperial (in)
 ⓘ = Metric (mm)

IC inserts sold in quantities of 10
 Insert screws sold in quantities of 10

A DRILLING
B BORING
C REAMING
D BURNISHING
E THREADING
X SPECIALS

4TEX Drill Holders | Imperial Shank

11 Series | Diameter Range: 1.260" - 1.535" (32.00mm - 38.99mm)

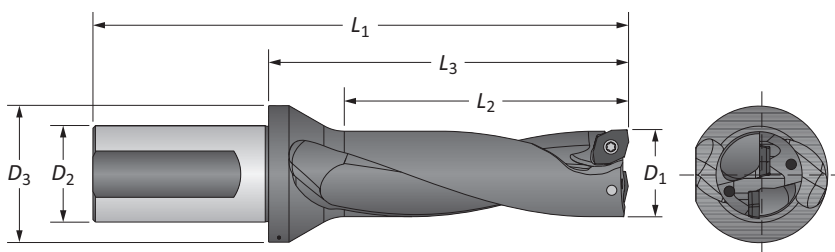

Imperial Shank

Length	Body				Shank		Max Offset	Part No.
	D_1	L_2	L_3	L_1	D_2	D_3		
2xD	32.00mm	2.520	3.953	6.669	1.500	2.126	0.087	D2113200M-150F
	33.00mm	2.598	4.031	6.748	1.500	2.126	0.075	D2113300M-150F
	34.00mm	2.677	4.110	6.827	1.500	2.126	0.067	D2113400M-150F
	1.375"	2.750	4.110	6.827	1.500	2.126	0.056	D2111375I-150F
	35.00mm	2.756	4.189	6.906	1.500	2.126	0.055	D2113500M-150F
	36.00mm	2.835	4.268	6.984	1.500	2.126	0.047	D2113600M-150F
	37.00mm	2.913	4.346	7.063	1.500	2.126	0.035	D2113700M-150F
	38.00mm	2.992	4.425	7.142	1.500	2.126	0.028	D2113800M-150F
1.500"	3.000	4.425	7.142	1.500	2.126	0.027	D2111500I-150F	
3xD	32.00mm	3.780	5.213	7.929	1.500	2.126	0.087	D3113200M-150F
	33.00mm	3.898	5.331	8.047	1.500	2.126	0.075	D3113300M-150F
	34.00mm	4.016	5.449	8.165	1.500	2.126	0.067	D3113400M-150F
	1.375"	4.125	5.449	8.165	1.500	2.126	0.056	D3111375I-150F
	35.00mm	4.134	5.567	8.283	1.500	2.126	0.055	D3113500M-150F
	36.00mm	4.252	5.685	8.402	1.500	2.126	0.047	D3113600M-150F
	37.00mm	4.370	5.803	8.520	1.500	2.126	0.035	D3113700M-150F
	38.00mm	4.488	5.921	8.638	1.500	2.126	0.028	D3113800M-150F
1.500"	4.500	5.921	8.638	1.500	2.126	0.027	D3111500I-150F	
4xD	32.00mm	5.039	6.079	8.795	1.500	2.126	0.087	D4113200M-150F
	33.00mm	5.197	6.236	8.953	1.500	2.126	0.075	D4113300M-150F
	34.00mm	5.354	6.394	9.110	1.500	2.126	0.067	D4113400M-150F
	1.375"	5.500	6.394	9.110	1.500	2.126	0.056	D4111375I-150F
	35.00mm	5.512	6.551	9.268	1.500	2.126	0.055	D4113500M-150F
	36.00mm	5.669	6.709	9.425	1.500	2.126	0.047	D4113600M-150F
	37.00mm	5.827	6.866	9.583	1.500	2.126	0.035	D4113700M-150F
	38.00mm	5.984	7.024	9.740	1.500	2.126	0.028	D4113800M-150F
1.500"	6.000	7.024	9.740	1.500	2.126	0.027	D4111500I-150F	

IC Inserts

ISO Material	Part No.	Insert Screw	Torx® Driver	Admissible Tightening Torque
P	4T-11T306-P	7488-T15-1	8T-15	30.9 in-lbs (3.5 N-cm)
S	4T-11T306-M			
M	4T-11T306-M			
H	4T-11T306-H			
K	4T-11T306-K			
N	4T-11T306-N			

A55: 26 - 27

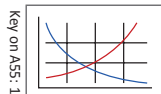

A55: 23 - 25



A55: 22

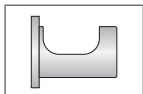

ⓘ = Imperial (in)
 ⓘ = Metric (mm)

IC inserts sold in quantities of 10
 Insert screws sold in quantities of 10

4TEX Drill Holders | Metric Shank

11 Series | Diameter Range: 1.260" - 1.535" (32.00mm - 38.99mm)

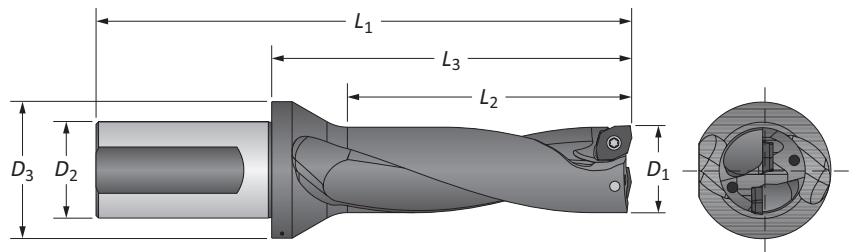

Metric Shank

Length	Body				Shank		Max Offset	Part No.
	D ₁	L ₂	L ₃	L ₁	D ₂	D ₃		
2xD	32.00mm	64.00	100.40	169.40	40.00	54.00	2.20	D2113200M-40FM
	33.00mm	66.00	102.40	171.40	40.00	54.00	1.90	D2113300M-40FM
	34.00mm	68.00	104.40	173.40	40.00	54.00	1.70	D2113400M-40FM
	1.375"	69.85	104.40	173.40	40.00	54.00	1.42	D211375I-40FM
	35.00mm	70.00	106.40	175.40	40.00	54.00	1.40	D2113500M-40FM
	36.00mm	72.00	108.40	177.40	40.00	54.00	1.20	D2113600M-40FM
	37.00mm	74.00	110.40	179.40	40.00	54.00	0.90	D2113700M-40FM
	38.00mm	76.00	112.40	181.40	40.00	54.00	0.70	D2113800M-40FM
1.500"	76.20	112.40	181.40	40.00	54.00	0.69	D2111500I-40FM	
3xD	32.00mm	96.00	132.40	201.40	40.00	54.00	2.20	D3113200M-40FM
	33.00mm	99.00	135.40	204.40	40.00	54.00	1.90	D3113300M-40FM
	34.00mm	102.00	138.40	207.40	40.00	54.00	1.70	D3113400M-40FM
	1.375"	104.78	138.40	207.40	40.00	54.00	1.42	D3111375I-40FM
	35.00mm	105.00	141.40	210.40	40.00	54.00	1.40	D3113500M-40FM
	36.00mm	108.00	144.40	213.40	40.00	54.00	1.20	D3113600M-40FM
	37.00mm	111.00	147.40	216.40	40.00	54.00	0.90	D3113700M-40FM
	38.00mm	114.00	150.40	219.40	40.00	54.00	0.70	D3113800M-40FM
1.500"	114.30	150.40	219.40	40.00	54.00	0.69	D3111500I-40FM	
4xD	32.00mm	128.00	154.40	223.40	40.00	54.00	2.20	D4113200M-40FM
	33.00mm	132.00	158.40	227.40	40.00	54.00	1.90	D4113300M-40FM
	34.00mm	136.00	162.40	231.40	40.00	54.00	1.70	D4113400M-40FM
	1.375"	139.70	162.40	231.40	40.00	54.00	1.42	D4111375I-40FM
	35.00mm	140.00	166.40	235.40	40.00	54.00	1.40	D4113500M-40FM
	36.00mm	144.00	170.40	239.40	40.00	54.00	1.20	D4113600M-40FM
	37.00mm	148.00	174.40	243.40	40.00	54.00	0.90	D4113700M-40FM
	38.00mm	152.00	178.40	247.40	40.00	54.00	0.70	D4113800M-40FM
1.500"	152.40	178.40	247.40	40.00	54.00	0.69	D4111500I-40FM	

IC Inserts

ISO Material	Part No.	Insert Screw	Torx® Driver	Admissible Tightening Torque
P	4T-11T306-P	7488-T15-1	8T-15	30.9 in-lbs (3.5 N-cm)
S M	4T-11T306-M			
H	4T-11T306-H			
K	4T-11T306-K			
N	4T-11T306-N			

Key on ASS-1

A55: 26 - 27

A55: 23 - 25

A55: 22

i = Imperial (in)
m = Metric (mm)
 IC inserts sold in quantities of 10
 Insert screws sold in quantities of 10

4TEX Drill Holders | Imperial Shank

14 Series | Diameter Range: 1.536" - 1.850" (39.00mm - 47.00mm)

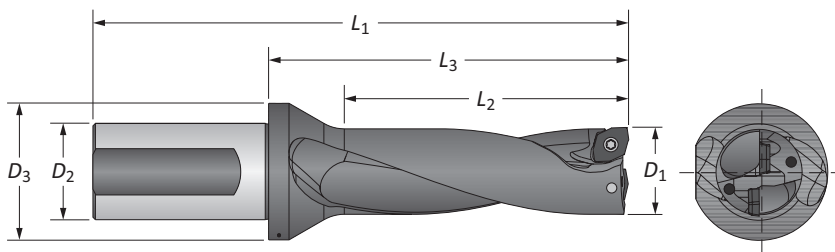

Imperial Shank

Length	Body				Shank		Max Offset	Part No.
	D ₁	L ₂	L ₃	L ₁	D ₂	D ₃		
2xD	39.00mm	3.071	4.346	7.063	1.500	2.126	0.110	D2143900M-150F
	40.00mm	3.150	4.425	7.142	1.500	2.126	0.098	D2144000M-150F
	41.00mm	3.228	4.504	7.220	1.500	2.126	0.091	D2144100M-150F
	1.625"	3.250	4.504	7.220	1.500	2.126	0.088	D2141625I-150F
	42.00mm	3.307	4.583	7.299	1.500	2.126	0.079	D2144200M-150F
	43.00mm	3.386	4.661	7.378	1.500	2.323	0.071	D2144300M-150F
	44.00mm	3.465	4.740	7.457	1.500	2.323	0.059	D2144400M-150F
	1.750"	3.500	4.740	7.457	1.500	2.323	0.055	D2141750I-150F
	45.00mm	3.543	4.819	7.535	1.500	2.323	0.051	D2144500M-150F
3xD	46.00mm	3.622	4.898	7.614	1.500	2.323	0.039	D2144600M-150F
	47.00mm	3.701	4.976	7.693	1.500	2.323	0.031	D2144700M-150F
	39.00mm	4.606	5.882	8.598	1.500	2.126	0.110	D3143900M-150F
	40.00mm	4.724	6.000	8.717	1.500	2.126	0.098	D3144000M-150F
	41.00mm	4.843	6.118	8.835	1.500	2.126	0.091	D3144100M-150F
	1.625"	4.875	6.118	8.835	1.500	2.126	0.088	D3141625I-150F
	42.00mm	4.961	6.236	8.953	1.500	2.126	0.079	D3144200M-150F
	43.00mm	5.079	6.354	9.071	1.500	2.323	0.071	D3144300M-150F
	44.00mm	5.197	6.472	9.189	1.500	2.323	0.059	D3144400M-150F
4xD	1.750"	5.250	6.472	9.189	1.500	2.323	0.055	D3141750I-150F
	45.00mm	5.315	6.591	9.307	1.500	2.323	0.051	D3144500M-150F
	46.00mm	5.433	6.709	9.425	1.500	2.323	0.039	D3144600M-150F
	47.00mm	5.551	6.827	9.543	1.500	2.323	0.031	D3144700M-150F
	39.00mm	6.142	7.417	10.134	1.500	2.126	0.110	D4143900M-150F
	40.00mm	6.299	7.575	10.291	1.500	2.126	0.098	D4144000M-150F
	41.00mm	6.457	7.732	10.449	1.500	2.126	0.091	D4144100M-150F
	1.625"	6.500	7.732	10.449	1.500	2.126	0.088	D4141625I-150F
	42.00mm	6.614	7.890	10.606	1.500	2.126	0.079	D4144200M-150F
4xD	43.00mm	6.772	8.047	10.764	1.500	2.323	0.071	D4144300M-150F
	44.00mm	6.929	8.205	10.921	1.500	2.323	0.059	D4144400M-150F
	1.750"	7.000	8.205	11.079	1.500	2.323	0.055	D4141750I-150F
	45.00mm	7.087	8.362	11.236	1.500	2.323	0.051	D4144500M-150F
	46.00mm	7.244	8.520	11.394	1.500	2.323	0.039	D4144600M-150F
	47.00mm	7.402	8.677	11.551	1.500	2.323	0.031	D4144700M-150F

IC Inserts

ISO Material	Part No.	Insert Screw	Torx® Driver	Admissible Tightening Torque
P	4T-140408-P	7595-T20-1	8T-20	39.8 in-lbs (4.5 N-cm)
S M	4T-140408-M			
H	4T-140408-H			
K	4T-140408-K			
N	4T-140408-N			

A55: 26 - 27

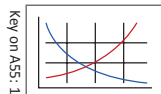

A55: 23 - 25



A55: 22

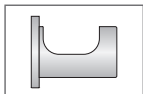

ⓘ = Imperial (in)

Ⓜ = Metric (mm)

IC inserts sold in quantities of 10
Insert screws sold in quantities of 10

4TEX Drill Holders | Metric Shank

14 Series | Diameter Range: 1.536" - 1.850" (39.00mm - 47.00mm)

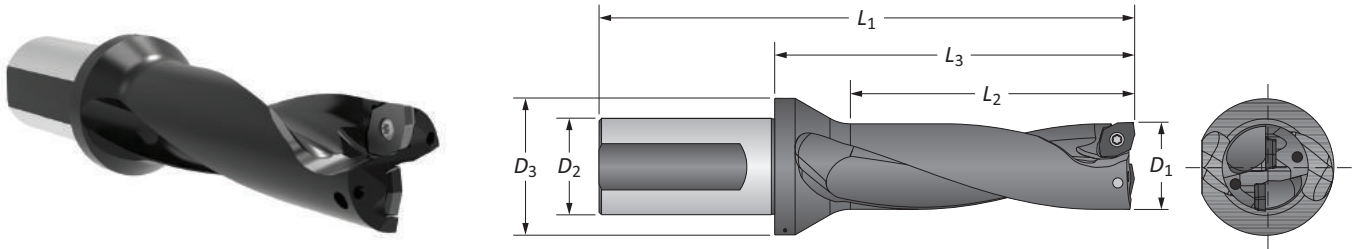

Metric Shank

Length	Body				Shank		Max Offset	Part No.
	D ₁	L ₂	L ₃	L ₁	D ₂	D ₃		
2xD	39.00mm	78.00	110.40	179.40	40.00	54.00	2.80	D2143900M-40FM
	40.00mm	80.00	112.40	181.40	40.00	54.00	2.50	D2144000M-40FM
	41.00mm	82.00	114.40	183.40	40.00	54.00	2.30	D2144100M-40FM
	1.625"	82.55	114.40	183.40	40.00	54.00	2.23	D2141625I-40FM
	42.00mm	84.00	116.40	185.40	40.00	54.00	2.00	D2144200M-40FM
	43.00mm	86.00	118.40	187.40	40.00	59.00	1.80	D2144300M-40FM
	44.00mm	88.00	120.40	189.40	40.00	59.00	1.50	D2144400M-40FM
	1.750"	88.90	120.40	189.40	40.00	59.00	1.41	D2141750I-40FM
	45.00mm	90.00	122.40	191.40	40.00	59.00	1.30	D2144500M-40FM
	46.00mm	92.00	124.40	193.40	40.00	59.00	1.00	D2144600M-40FM
47.00mm	94.00	126.40	195.40	40.00	59.00	0.80	D2144700M-40FM	
3xD	39.00mm	117.00	149.40	218.40	40.00	54.00	2.80	D3143900M-40FM
	40.00mm	120.00	152.40	221.40	40.00	54.00	2.50	D3144000M-40FM
	41.00mm	123.00	155.40	224.40	40.00	54.00	2.30	D3144100M-40FM
	1.625"	123.83	155.40	224.40	40.00	54.00	2.23	D3141625I-40FM
	42.00mm	126.00	158.40	227.40	40.00	54.00	2.00	D3144200M-40FM
	43.00mm	129.00	161.40	230.40	40.00	59.00	1.80	D3144300M-40FM
	44.00mm	132.00	164.40	233.40	40.00	59.00	1.50	D3144400M-40FM
	1.750"	133.35	164.40	233.40	40.00	59.00	1.41	D3141750I-40FM
	45.00mm	135.00	167.40	236.40	40.00	59.00	1.30	D3144500M-40FM
	46.00mm	138.00	170.40	239.40	40.00	59.00	1.00	D3144600M-40FM
47.00mm	141.00	173.40	242.40	40.00	59.00	0.80	D3144700M-40FM	
4xD	39.00mm	156.00	188.40	257.40	40.00	54.00	2.80	D4143900M-40FM
	40.00mm	160.00	192.40	261.40	40.00	54.00	2.50	D4144000M-40FM
	41.00mm	164.00	196.40	265.40	40.00	54.00	2.30	D4144100M-40FM
	1.625"	165.10	196.40	265.40	40.00	54.00	2.23	D4141625I-40FM
	42.00mm	168.00	200.40	269.40	40.00	54.00	2.00	D4144200M-40FM
	43.00mm	172.00	204.40	273.40	40.00	59.00	1.80	D4144300M-40FM
	44.00mm	176.00	208.40	277.40	40.00	59.00	1.50	D4144400M-40FM
	1.750"	177.80	208.40	277.40	40.00	59.00	1.41	D4141750I-40FM
	45.00mm	180.00	212.40	281.40	40.00	59.00	1.30	D4144500M-40FM
	46.00mm	184.00	216.40	285.40	40.00	59.00	1.00	D4144600M-40FM
47.00mm	188.00	220.40	289.40	40.00	59.00	0.80	D4144700M-40FM	

IC Inserts

ISO Material	Part No.	Insert Screw	Torx® Driver	Admissible Tightening Torque
P	4T-140408-P	7595-T20-1	8T-20	39.8 in-lbs (4.5 N-cm)
S M	4T-140408-M			
H	4T-140408-H			
K	4T-140408-K			
N	4T-140408-N			

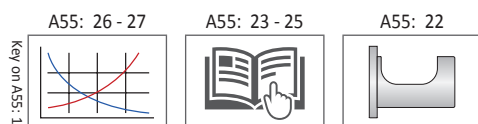

ⓘ = Imperial (in)
 ⓘ = Metric (mm)

IC inserts sold in quantities of 10
 Insert screws sold in quantities of 10

Eccentric Sleeves

For Cutting Diameter / Center Height Adjustment

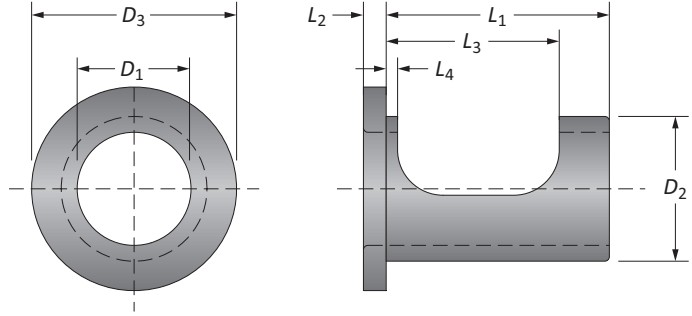

Sleeve Dimensions							Adjustment Range		
D_1	D_2	D_3	L_2	L_3	L_4	L_1	Part No.	Diameter*	Center Height
0.750	1.000	1.614	0.157	1.417	0.118	1.536	SLEEVE-075F	+0.0157 to -0.0079	+0.0079 to -0.0059
1.000	1.250	1.929	0.236	1.496	0.098	1.890	SLEEVE-100F	+0.0157 to -0.0079	+0.0079 to -0.0059
1.250	1.500	2.283	0.236	1.693	0.098	2.087	SLEEVE-125F	+0.0157 to -0.0079	+0.0079 to -0.0059
1.500	2.000	2.913	0.236	1.929	0.118	2.481	SLEEVE-150F	+0.0236 to -0.0079	+0.0079 to -0.0079
<hr/>									
20.00	25.00	41.00	4.00	36.00	3.00	43.00	SLEEVE-20FM	+0.40 to -0.20	+0.20 to -0.15
25.00	32.00	49.00	6.00	38.00	2.50	48.00	SLEEVE-25FM	+0.40 to -0.20	+0.20 to -0.15
32.00	40.00	58.00	6.00	43.00	2.50	53.00	SLEEVE-32FM	+0.40 to -0.20	+0.20 to -0.15
40.00	50.00	74.00	6.00	49.00	3.00	63.00	SLEEVE-40FM	+0.40 to -0.20	+0.20 to -0.20

*Diameter adjustment range refers to the cutting diameter.

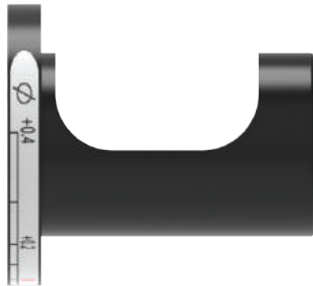

Milling Applications
Peripheral Adjustment Position

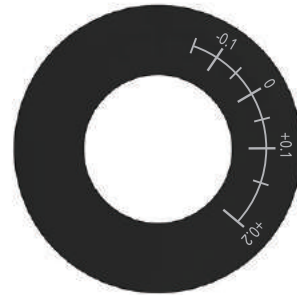

Lathe Applications
Front Adjustment Position

i = Imperial (in)
m = Metric (mm)

Eccentric Sleeves

Diameter Adjustment

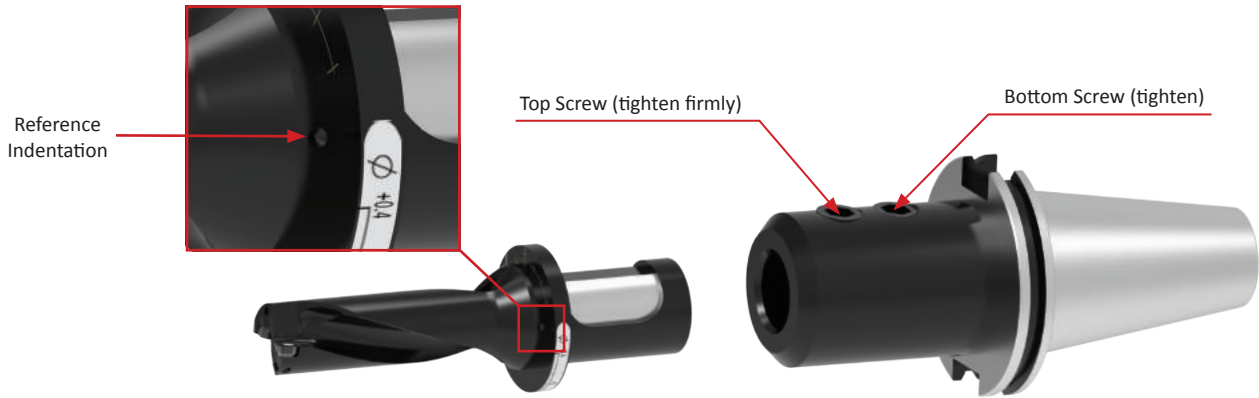

For Milling Applications

1. Assemble the 4TEX Drill, eccentric sleeve, and tool holder. Do not tighten the tool holder set screws.
2. Using the peripheral marks for milling machines, align the reference indentation on the holder with the 0 (zero) mark on the eccentric sleeve to have no offset.
3. Rotate the sleeve in the (+) or (-) direction to increase or decrease the nominal diameter.
4. Once the drill has arrived at the desired diameter, firmly tighten the top set screw first and then tighten the bottom set screw.

NOTICE: Eccentric sleeves are to be used with side-locking tool holders only. Damage may result with other styles of tool holders.

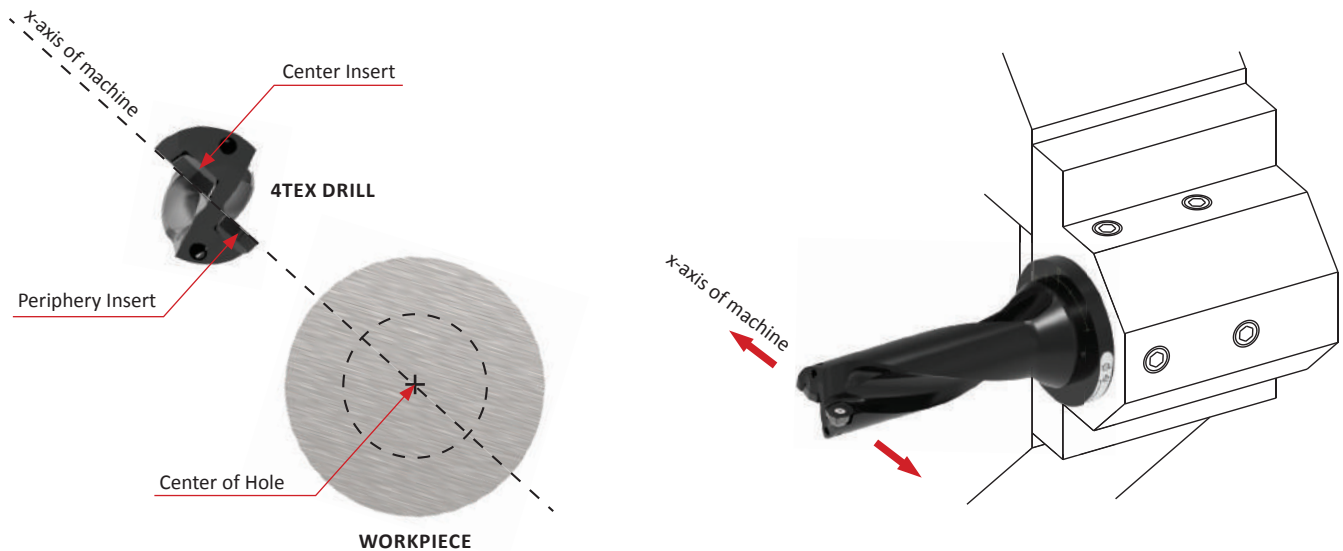

For Lathe Applications

1. Assemble the 4TEX Drill into the lathe turret with the top face of the inserts parallel to the x-axis of the machine. This will allow for the diameter offsets to be made using the lathe's x-axis.
2. To increase the nominal diameter, offset the x-axis so the periphery insert moves away from the center of the hole.
3. To decrease the nominal diameter, offset the x-axis so the periphery insert moves toward the center of the hole.

Center Height Alignment

Proper Center Line Position

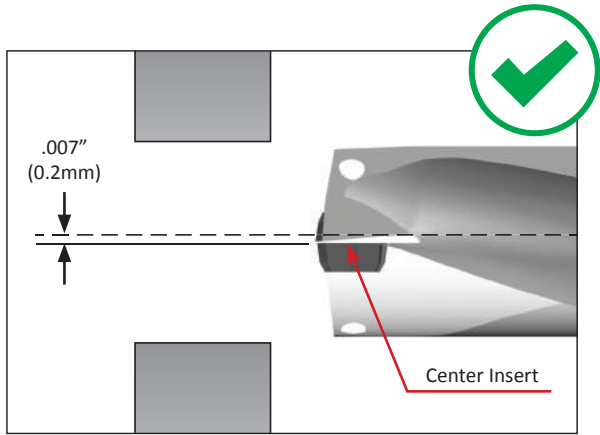
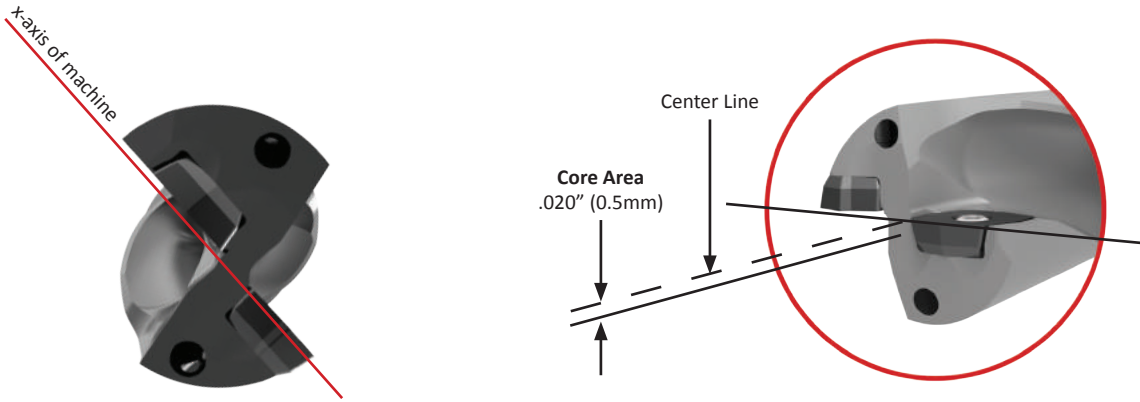

Proper Center Height Alignment

- The correct center height alignment will position the center insert .007" (0.2mm) below the center line.

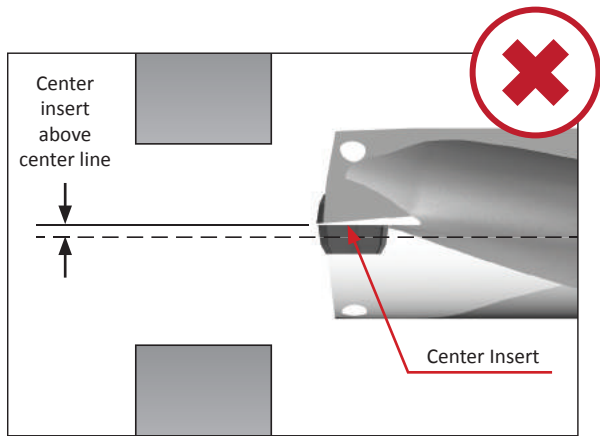
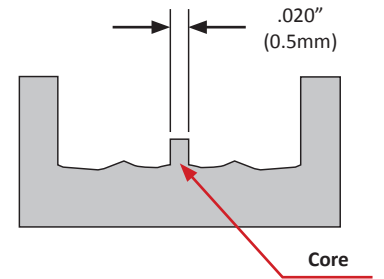

Center Insert Above the Center Line

- This will cause fracturing of the center insert
- Requires center height adjustment

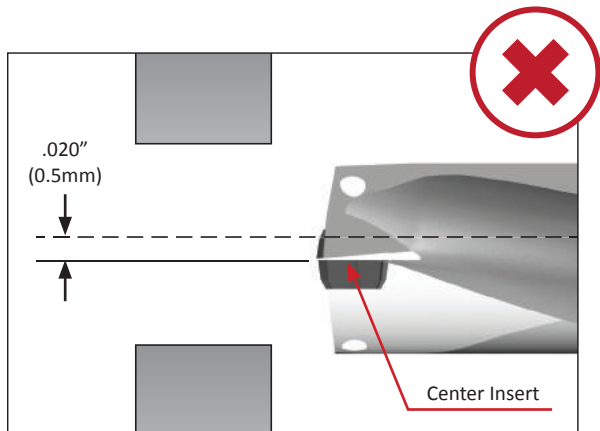
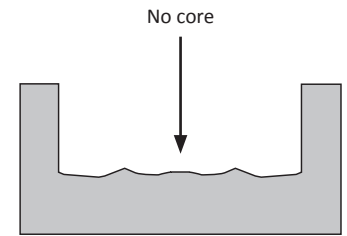

Center Insert Too Far Below Center Line

- This will cause the drill to interfere with the drilled hole
- This will impede chip evacuation on the periphery insert
- Requires center height adjustment

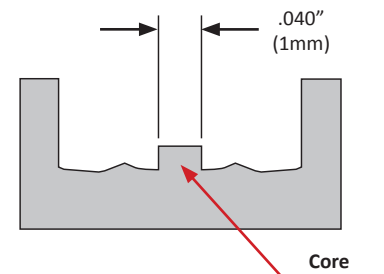

A DRILLING
B BORING
C REAMING
D BURNISHING
E THREADING
X SPECIALS

Center Height Alignment

How to Correct Issues

A

DRILLING

B

BORING

C

REAMING

D

BURNISHING

E

THREADING

X

SPECIALS

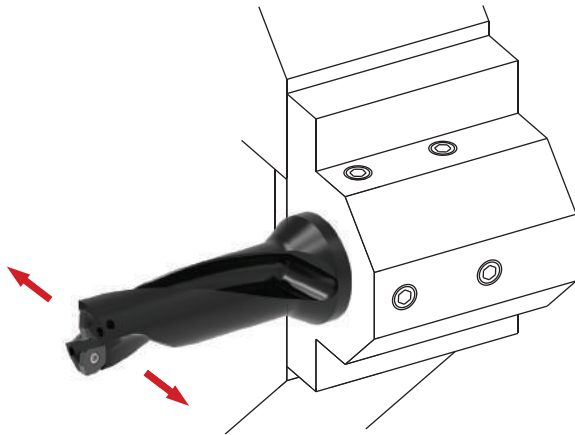

Method 1: Adjustment with X-Axis

1. Rotate the drill body so the position of the center line of the inserts is perpendicular to the lathe's x-axis.
2. Use the x-axis to offset the position of the center line in a (+) or (-) direction to increase or decrease the center core diameter at the bottom of the hole.

NOTE: This method does not allow diameter adjustments using the x-axis.

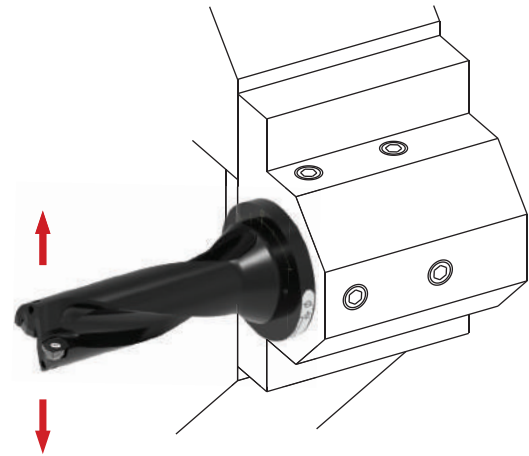

Method 2: Adjustment with Eccentric Sleeve

1. Assemble the drill to the turret using the eccentric sleeve, positioning the center line of the inserts parallel to the x-axis.
2. Align the reference indentation on the drill to the "0" setting on the flange face.
2. Rotate the sleeve (+) or (-) to increase or decrease the center height of the inserts in order to increase or decrease the core diameter at the bottom of the hole.

NOTE: This method still allows diameter adjustments using the x-axis.

NOTE (applies to both methods): Adjusting the center line of the inserts may affect the hole diameter produced. Method 2 is preferred to make center height adjustments and compensate for hole diameter with the x-axis.

Recommended Drilling Data | Imperial (inch)

ISO	Material	Hardness (BHN)	Speed (SFM)				Feed Rate (IPR) by Diameter - 2xD, 3xD**			
			P	K	H	M	N	.432 - .591	.630 - .709	.748 - 1.024
			AM480	AM485	TiCN					
P	Free Machining Steel 1118, 1215, 12L14, etc.	100 - 150	–	400 - 1200	–	.0024 - .0039	.0024 - .0047	.0031 - .0055	.0031 - .0055	
		150 - 200	–	400 - 1000	–	.0024 - .0039	.0024 - .0047	.0031 - .0055	.0031 - .0055	
		200 - 250	400 - 800	400 - 800	–	.0024 - .0039	.0024 - .0047	.0031 - .0055	.0031 - .0055	
	Low Carbon Steel 1010, 1020, 1025, 1522, 1144, etc.	85 - 125	–	400 - 1000	–	.0024 - .0039	.0024 - .0047	.0031 - .0055	.0031 - .0055	
		125 - 175	–	400 - 1000	–	.0024 - .0039	.0024 - .0047	.0031 - .0055	.0031 - .0055	
		175 - 225	–	400 - 800	–	.0024 - .0039	.0024 - .0047	.0031 - .0055	.0031 - .0055	
	Medium Carbon Steel 1030, 1040, 1050, 1527, 1140, 1151, etc.	225 - 275	400 - 800	400 - 800	–	.0024 - .0039	.0024 - .0047	.0031 - .0055	.0031 - .0055	
		125 - 175	–	330 - 800	–	.0016 - .0055	.0024 - .0063	.0031 - .0080	.0031 - .0080	
		175 - 225	–	330 - 800	–	.0016 - .0055	.0024 - .0063	.0031 - .0080	.0031 - .0080	
	Alloy Steel 4140, 5140, 8640, etc.	225 - 275	–	330 - 800	–	.0016 - .0055	.0024 - .0063	.0031 - .0080	.0031 - .0080	
		275 - 325	330 - 800	–	–	.0016 - .0055	.0024 - .0063	.0031 - .0080	.0031 - .0080	
		325 - 375	330 - 800	–	–	.0016 - .0055	.0024 - .0063	.0031 - .0080	.0031 - .0080	
	High Strength Alloy 4340, 4330V, 300M, etc.	275 - 325	330 - 800	–	–	.0016 - .0055	.0024 - .0063	.0031 - .0080	.0031 - .0080	
		325 - 375	330 - 800	–	–	.0016 - .0055	.0024 - .0063	.0031 - .0080	.0031 - .0080	
		375 - 425	330 - 800	–	–	.0016 - .0055	.0024 - .0063	.0031 - .0080	.0031 - .0080	
	Structural Steel A36, A285, A516, etc.	225 - 300	330 - 600	–	–	.0016 - .0055	.0024 - .0063	.0031 - .0080	.0031 - .0080	
		300 - 350	330 - 600	–	–	.0016 - .0055	.0024 - .0063	.0031 - .0080	.0031 - .0080	
		350 - 400	330 - 600	–	–	.0016 - .0055	.0024 - .0063	.0031 - .0080	.0031 - .0080	
Tool Steel H-13, H-21, A-4, O-2, S-3, etc.	100 - 150	330 - 600	–	–	.0016 - .0050	.0024 - .0050	.0031 - .0050	.0031 - .0050		
	150 - 200	330 - 600	–	–	.0016 - .0050	.0024 - .0050	.0031 - .0050	.0031 - .0050		
	200 - 250	330 - 600	–	–	.0016 - .0050	.0024 - .0050	.0031 - .0050	.0031 - .0050		
S	High Temp Alloy* Hastelloy B, Inconel 600, etc.	150 - 200	270 - 600	–	–	.0016 - .0031	.0024 - .0047	.0031 - .0059	.0031 - .0059	
		200 - 250	270 - 600	–	–	.0016 - .0031	.0024 - .0047	.0031 - .0059	.0031 - .0059	
	Titanium Alloy*	140 - 220	–	100 - 250	–	.0020 - .0031	.0020 - .0031	.0024 - .0039	.0024 - .0039	
		220 - 310	–	100 - 200	–	.0020 - .0031	.0020 - .0031	.0024 - .0039	.0024 - .0039	
		310 - 400	–	100 - 200	–	.0020 - .0031	.0020 - .0031	.0024 - .0039	.0024 - .0039	
Aerospace Alloy* S82	140 - 500	–	140 - 500	–	.0020 - .0031	.0020 - .0031	.0024 - .0039	.0024 - .0039		
	500 - 600	–	140 - 300	–	.0020 - .0031	.0020 - .0031	.0024 - .0039	.0024 - .0039		
M	Stainless Steel 400 Series 416, 420, etc.	185 - 275	240 - 600	240 - 700	–	.0016 - .0039	.0024 - .0047	.0024 - .0055	.0024 - .0055	
		275 - 350	240 - 470	240 - 500	–	.0016 - .0039	.0024 - .0047	.0024 - .0055	.0024 - .0055	
	Stainless Steel 300 Series 304, 316, 17-4PH, etc.	135 - 185	240 - 600	240 - 700	–	.0016 - .0039	.0024 - .0047	.0024 - .0055	.0024 - .0055	
		185 - 275	240 - 470	240 - 500	–	.0016 - .0039	.0024 - .0047	.0024 - .0055	.0024 - .0055	
	Super Duplex Stainless Steel	–	240 - 600	240 - 700	–	.0016 - .0039	.0024 - .0047	.0024 - .0055	.0024 - .0055	
–		240 - 470	240 - 500	–	.0016 - .0039	.0024 - .0047	.0024 - .0055	.0024 - .0055		
H	Wear Plate Hardox, AR400, T-1, etc.	400	100 - 200	–	–	.0016 - .0031	.0024 - .0047	.0031 - .0059	.0031 - .0059	
		500	100 - 200	–	–	.0016 - .0031	.0024 - .0047	.0031 - .0059	.0031 - .0059	
		600	100 - 200	–	–	.0016 - .0031	.0024 - .0047	.0031 - .0059	.0031 - .0059	
	Hardened Steel	300 - 400	100 - 300	–	–	.0016 - .0031	.0024 - .0047	.0031 - .0059	.0031 - .0059	
400 - 500		100 - 200	–	–	.0016 - .0031	.0024 - .0047	.0031 - .0059	.0031 - .0059		
K	Nodular, Grey, Ductile Cast Iron	120 - 150	300 - 800	–	–	.0031 - .0055	.0031 - .0071	.0031 - .0079	.0031 - .0080	
		150 - 200	300 - 800	–	–	.0031 - .0055	.0031 - .0071	.0031 - .0079	.0031 - .0080	
		200 - 220	300 - 500	–	–	.0031 - .0055	.0031 - .0071	.0031 - .0079	.0031 - .0080	
		220 - 260	270 - 400	–	–	.0031 - .0055	.0031 - .0071	.0031 - .0079	.0031 - .0080	
		260 - 320	270 - 400	–	–	.0031 - .0055	.0031 - .0071	.0031 - .0079	.0031 - .0080	
N	Cast Aluminum	30	–	–	800 - 2000	.0024 - .0047	.0031 - .0055	.0031 - .0063	.0031 - .0080	
		180	–	–	800 - 2000	.0024 - .0047	.0031 - .0055	.0031 - .0063	.0031 - .0080	
	Wrought Aluminum	30	–	–	800 - 2000	.0024 - .0047	.0031 - .0055	.0031 - .0063	.0031 - .0080	
		180	–	–	800 - 2000	.0024 - .0047	.0031 - .0055	.0031 - .0063	.0031 - .0080	
	Aluminum Bronze	100 - 200	–	–	500 - 1000	.0024 - .0047	.0031 - .0055	.0031 - .0063	.0031 - .0080	
		200 - 250	–	–	500 - 1000	.0024 - .0047	.0031 - .0055	.0031 - .0063	.0031 - .0080	
	Brass	100	–	–	500 - 1000	.0024 - .0047	.0031 - .0055	.0031 - .0063	.0031 - .0080	
Copper	60	–	–	500 - 1000	.0024 - .0047	.0031 - .0055	.0031 - .0063	.0031 - .0080		

*For high temp materials, 1000 PSI is recommended as well as a quality synthetic coolant at approximately 10% emulsion.

**For 4xD tools, begin at low end of feed recommendation.

IMPORTANT: The speeds and feeds listed above are a general starting point for all applications. Factory technical assistance is also available through our Application Engineering Team.

Recommended Drilling Data | Metric (mm)

ISO	Material	Hardness (BHN)	Speed (M/min)					Feed Rate (mm/rev) by Diameter - 2xD, 3xD**			
			P	K	H	M	N	12.00 - 15.00	15.50 - 18.00	18.50 - 26.00	26.00 - 47.00
			AM480	AM485	TiCN						
P	Free Machining Steel 1118, 1215, 12L14, etc.	100 - 150	-	122 - 365	-	0.07 - 0.10	0.07 - 0.12	0.08 - 0.14	0.08 - 0.14		
		150 - 200	-	122 - 305	-	0.07 - 0.10	0.07 - 0.12	0.08 - 0.14	0.08 - 0.14		
		200 - 250	122 - 245	122 - 245	-	0.07 - 0.10	0.07 - 0.12	0.08 - 0.14	0.08 - 0.14		
	Low Carbon Steel 1010, 1020, 1025, 1522, 1144, etc.	85 - 125	-	122 - 305	-	0.07 - 0.10	0.07 - 0.12	0.08 - 0.14	0.08 - 0.14		
		125 - 175	-	122 - 305	-	0.07 - 0.10	0.07 - 0.12	0.08 - 0.14	0.08 - 0.14		
		175 - 225	-	122 - 245	-	0.07 - 0.10	0.07 - 0.12	0.08 - 0.14	0.08 - 0.14		
		225 - 275	122 - 245	122 - 245	-	0.07 - 0.10	0.07 - 0.12	0.08 - 0.14	0.08 - 0.14		
	Medium Carbon Steel 1030, 1040, 1050, 1527, 1140, 1151, etc.	125 - 175	-	100 - 245	-	0.05 - 0.14	0.07 - 0.17	0.08 - 0.21	0.08 - 0.21		
		175 - 225	-	100 - 245	-	0.05 - 0.14	0.07 - 0.17	0.08 - 0.21	0.08 - 0.21		
		225 - 275	-	100 - 245	-	0.05 - 0.14	0.07 - 0.17	0.08 - 0.21	0.08 - 0.21		
		275 - 325	100 - 245	100 - 183	-	0.05 - 0.14	0.07 - 0.17	0.08 - 0.21	0.08 - 0.21		
	Alloy Steel 4140, 5140, 8640, etc.	125 - 175	100 - 245	-	-	0.05 - 0.14	0.07 - 0.17	0.08 - 0.21	0.08 - 0.21		
		175 - 225	100 - 245	-	-	0.05 - 0.14	0.07 - 0.17	0.08 - 0.21	0.08 - 0.21		
		225 - 275	100 - 245	-	-	0.05 - 0.14	0.07 - 0.17	0.08 - 0.21	0.08 - 0.21		
		275 - 325	100 - 245	-	-	0.05 - 0.14	0.07 - 0.17	0.08 - 0.21	0.08 - 0.21		
		325 - 375	100 - 245	-	-	0.05 - 0.14	0.07 - 0.17	0.08 - 0.21	0.08 - 0.21		
	High Strength Alloy 4340, 4330V, 300M, etc.	225 - 300	100 - 163	-	-	0.05 - 0.14	0.07 - 0.17	0.08 - 0.21	0.08 - 0.21		
		300 - 350	101 - 183	-	-	0.05 - 0.14	0.07 - 0.17	0.08 - 0.21	0.08 - 0.21		
350 - 400		101 - 183	-	-	0.05 - 0.14	0.07 - 0.17	0.08 - 0.21	0.08 - 0.21			
Structural Steel A36, A285, A516, etc.	100 - 150	101 - 183	-	-	0.05 - 0.13	0.07 - 0.13	0.08 - 0.13	0.08 - 0.13			
	150 - 250	101 - 183	-	-	0.05 - 0.13	0.07 - 0.13	0.08 - 0.13	0.08 - 0.13			
	250 - 350	101 - 183	-	-	0.05 - 0.13	0.07 - 0.13	0.08 - 0.13	0.08 - 0.13			
Tool Steel H-13, H-21, A-4, O-2, S-3, etc.	150 - 200	83 - 183	-	-	0.05 - 0.08	0.07 - 0.12	0.08 - 0.15	0.08 - 0.15			
	200 - 250	83 - 183	-	-	0.05 - 0.08	0.07 - 0.12	0.08 - 0.15	0.08 - 0.15			
S	High Temp Alloy* Hastelloy B, Inconel 600, etc.	140 - 220	-	31 - 77	-	0.06 - 0.08	0.06 - 0.08	0.07 - 0.10	0.07 - 0.10		
		220 - 310	-	31 - 61	-	0.06 - 0.08	0.06 - 0.08	0.07 - 0.10	0.07 - 0.10		
	Titanium Alloy*	140 - 220	-	43 - 153	-	0.06 - 0.08	0.06 - 0.08	0.07 - 0.10	0.07 - 0.10		
		220 - 310	-	43 - 92	-	0.06 - 0.08	0.06 - 0.08	0.07 - 0.10	0.07 - 0.10		
	Aerospace Alloy* S82	185 - 275	-	31 - 77	-	0.06 - 0.08	0.06 - 0.08	0.07 - 0.10	0.07 - 0.10		
275 - 350		-	31 - 61	-	0.06 - 0.08	0.06 - 0.08	0.07 - 0.10	0.07 - 0.10			
M	Stainless Steel 400 Series 416, 420, etc.	185 - 275	74 - 183	74 - 214	-	0.05 - 0.10	0.07 - 0.12	0.07 - 0.14	0.07 - 0.14		
		275 - 350	74 - 144	74 - 153	-	0.05 - 0.10	0.07 - 0.12	0.07 - 0.14	0.07 - 0.14		
	Stainless Steel 300 Series 304, 316, 17-4PH, etc.	135 - 185	74 - 183	74 - 214	-	0.05 - 0.10	0.07 - 0.12	0.07 - 0.14	0.07 - 0.14		
		185 - 275	74 - 144	74 - 153	-	0.05 - 0.10	0.07 - 0.12	0.07 - 0.14	0.07 - 0.14		
	Super Duplex Stainless Steel	74 - 183	74 - 214	-	0.05 - 0.10	0.07 - 0.12	0.07 - 0.14	0.07 - 0.14			
135 - 275		74 - 144	74 - 153	-	0.05 - 0.10	0.07 - 0.12	0.07 - 0.14	0.07 - 0.14			
H	Wear Plate Hardox, AR400, T-1, etc.	400	31 - 61	-	-	0.05 - 0.08	0.07 - 0.12	0.08 - 0.15	0.08 - 0.15		
		500	31 - 61	-	-	0.05 - 0.08	0.07 - 0.12	0.08 - 0.15	0.08 - 0.15		
		600	31 - 61	-	-	0.05 - 0.08	0.07 - 0.12	0.08 - 0.15	0.08 - 0.15		
	Hardened Steel	300 - 400	31 - 92	-	-	0.05 - 0.08	0.07 - 0.12	0.08 - 0.15	0.08 - 0.15		
400 - 500		31 - 61	-	-	0.05 - 0.08	0.07 - 0.12	0.08 - 0.15	0.08 - 0.15			
K	Nodular, Grey, Ductile Cast Iron	120 - 150	92 - 244	-	-	0.08 - 0.14	0.08 - 0.19	0.08 - 0.21	0.08 - 0.21		
		150 - 200	92 - 244	-	-	0.08 - 0.14	0.08 - 0.19	0.08 - 0.21	0.08 - 0.21		
		200 - 220	92 - 153	-	-	0.08 - 0.14	0.08 - 0.19	0.08 - 0.21	0.08 - 0.21		
		220 - 260	83 - 122	-	-	0.08 - 0.14	0.08 - 0.19	0.08 - 0.21	0.08 - 0.21		
		260 - 320	83 - 122	-	-	0.08 - 0.14	0.08 - 0.19	0.08 - 0.21	0.08 - 0.21		
N	Cast Aluminum	30	-	-	244 - 610	0.07 - 0.12	0.08 - 0.14	0.08 - 0.17	0.08 - 0.21		
		180	-	-	244 - 610	0.07 - 0.12	0.08 - 0.14	0.08 - 0.17	0.08 - 0.21		
	Wrought Aluminum	30	-	-	244 - 610	0.07 - 0.12	0.08 - 0.14	0.08 - 0.17	0.08 - 0.21		
		180	-	-	244 - 610	0.07 - 0.12	0.08 - 0.14	0.08 - 0.17	0.08 - 0.21		
	Aluminum Bronze	100 - 200	-	-	153 - 305	0.07 - 0.12	0.08 - 0.14	0.08 - 0.17	0.08 - 0.21		
		200 - 250	-	-	153 - 305	0.07 - 0.12	0.08 - 0.14	0.08 - 0.17	0.08 - 0.21		
	Brass	100	-	-	153 - 305	0.07 - 0.12	0.08 - 0.14	0.08 - 0.17	0.08 - 0.21		
Copper	60	-	-	153 - 305	0.07 - 0.12	0.08 - 0.14	0.08 - 0.17	0.08 - 0.21			

*For high temp materials, 68.95 bar is recommended as well as a quality synthetic coolant at approximately 10% emulsion.

**For 4xD tools, begin at low end of feed recommendation.

IMPORTANT: The speeds and feeds listed above are a general starting point for all applications. Factory technical assistance is also available through our Application Engineering Team.

A DRILLING B BORING C REAMING D BURNISHING E THREADING X SPECIALS



Insert Geometry Recommendations

ISO	Material	Hardness (BHN)	Geometry				
			P	M	K	N	H
P	Free Machining Steel 1118, 1215, 12L14, etc.	100 - 150	○	●			
		150 - 200	●	○			
		200 - 250	●	○			
	Low Carbon Steel 1010, 1020, 1025, 1522, 1144, etc.	85 - 125	○	●			
		125 - 175	○	●			
		175 - 225	○	●			
		225 - 275	●	○			
	Medium Carbon Steel 1030, 1040, 1050, 1527, 1140, 1151, etc.	125 - 175	○	●			
		175 - 225	○	●			
		225 - 275	●	○			
	Alloy Steel 4140, 5140, 8640, etc.	125 - 175	○	●			
		175 - 225	●	○			
		225 - 275	●				○
		275 - 325	●				○
		325 - 375	○				●
	High Strength Alloy 4340, 4330V, 300M, etc.	225 - 300	●				
		300 - 350	○				●
		350 - 400	○				●
Structural Steel A36, A285, A516, etc.	100 - 150	○	●				
	150 - 250	○	●				
	250 - 350	●				○	
Tool Steel H-13, H-21, A-4, O-2, S-3, etc.	150 - 200	●	○				
	200 - 250	●				○	
S	High Temp Alloy* Hastelloy B, Inconel 600, etc.	140 - 220	○	●			
		220 - 310	○	●			
	Titanium Alloy*	140 - 220	○	●			
		220 - 310	○	●			
	Aerospace Alloy* S82	185 - 275	○	●			
275 - 350		○	●				
M	Stainless Steel 400 Series 416, 420, etc.	185 - 275	○	●			
		275 - 350	○	●			
	Stainless Steel 300 Series 304, 316, 17-4PH, etc.	135 - 185	○	●			
		185 - 275	○	●			
	Super Duplex Stainless Steel		○	●			
	135 - 275	○	●				
H	Wear Plate Hardox, AR400, T-1, etc.	400	○				●
		500	○				●
		600	○				●
	Hardened Steel	300 - 400	○				●
400 - 500		○				●	
K	Nodular, Ductile Cast Iron	120 - 150	●	○			
		150 - 200	●	○			
		200 - 220	●	○			
		220 - 260					○
		260 - 320			●		○
	Grey / White Iron	120 - 150				●	○
		150 - 200				●	○
		200 - 220				●	
		220 - 260				●	
	260 - 320				●		
N	Cast Aluminum	30				●	
		180				●	
	Wrought Aluminum	30				●	
		180				●	
	Aluminum Bronze	100 - 200	○			●	
		200 - 250	○			●	
	Brass	100	○			●	
Copper	60				●		

Troubleshooting

1.

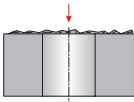

Starting on Uneven Surfaces

 - Reduce entry feed by 50% if necessary
2.



Starting on Angled Surfaces

 - Reduce entry feed by 20 - 50%
 - Use lower rake geometry if insert chipping occurs
3.

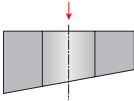

Angled Bore Exit

 - Reduce entry feed by 50% on breakout
 - Use tough insert and stable corner radius
4.

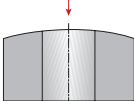

Starting on Convex Surfaces

 - Reduce entry feed by 50%
 - Use lower rake geometry if insert chipping occurs
5.

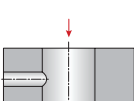

Drilling through a Cross Hole

 - Reduce feed rate 50% if necessary
 - Use good coolant flow and monitor chip packing
 - Use lower rake geometry if insert chipping occurs
6.

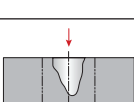

Drilling on a Groove or Large Centering Box

 - Reduce entry feed
 - Use lower rake geometry for center insert
7.

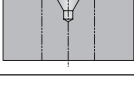

Chain Drilling

 - Use good coolant flow
 - Reduce feed rate by 50% for interrupted cut
 - Use lower rake geometry if insert chipping occurs
8.

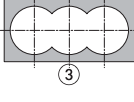

Starting on an Edge

 - Reduce entry feed rate by 50%
 - Use lower rake geometry if insert chipping occurs
9.

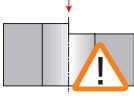

Starting on a Welded Seam

 - Reduce entry feed rate by 50%
 - Use lower rake geometry if insert chipping occurs
10.

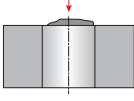

Drilling through Stacked Plates

 - Not recommended
11.

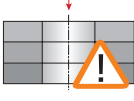

Opening an Existing Hole

 - Use flood coolant
12.

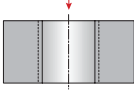

Adjustable

 - For mills, use eccentric sleeve with end mill holder
 - For lathes, use x-axis to adjust offset ϕ

NOTE: Refer to maximum offset ϕ in data tables

A

DRILLING

B

BORING

C

REAMING

D

BURNISHING

E

THREADING

X

SPECIALS

Guaranteed Test / Demo Application Form

Distributor PO # _____

The following must be filled out completely before your test will be considered

IMPORTANT: For processing, send Purchase Order to your Allied Field Sales Engineer (FSE). Please clearly mark the paperwork as "Test Order."

Distributor Information

Company Name: _____
 Contact: _____
 Account Number: _____
 Phone: _____
 Email: _____

End User Information

Company Name: _____
 Contact: _____
 Industry: _____
 Phone: _____
 Email: _____

Current Process List all tooling, coatings, substrates, speeds and feeds, tool life, and any problems you are experiencing

Test Objective List what would make this a successful test (i.e. penetration rate, finish, tool life, hole size, etc.)

Application Information

Hole Diameter: _____ in/mm	Tolerance: _____	Material: _____ (4150 / A36 / Cast Iron / etc.)
Pre-existing Diameter: _____ in/mm	Depth of Cut: _____ in/mm	Hardness: _____ (BHN / Rc)
Required Finish: _____ RMS	State: _____ (Casting / Hot rolled / Forging)	

Machine Information

Machine Type: _____ (Lathe / Screw machine / Machine center / etc.)	Builder: _____ (Haas, Mori Seiki, etc.)	Model #: _____
Shank Required: _____ (CAT50 / Morse taper, etc.)	Power: _____ HP/KW	
Rigidity: _____	Orientation: _____	Tool Rotating: _____
<input type="checkbox"/> Excellent	<input type="checkbox"/> Vertical	<input type="checkbox"/> Yes
<input type="checkbox"/> Good	<input type="checkbox"/> Horizontal	<input type="checkbox"/> No
<input type="checkbox"/> Poor	Thrust: _____ lbs/N	

Coolant Information

Coolant Delivery: _____ (Through tool / Flood)	Coolant Pressure: _____ PSI / bar
Coolant Type: _____ (Air mist, oil, synthetic, water soluble, etc.)	Coolant Volume: _____ GPM / LPM

Requested Tooling

QTY	Item Number	QTY	Item Number



Allied Machine & Engineering
 120 Deeds Drive
 Dover, OH 44622

Telephone: (330) 343-4283
Toll Free USA & Canada: (800) 321-5537
Fax: (330) 602-3400
Email: info@alliedmachine.com

Warranty Information

Allied Machine & Engineering warrants to original equipment manufacturers, distributors, industrial and commercial users of its products that each new product manufactured or supplied by Allied Machine shall be free from defects in material and workmanship.

Allied Machine's obligation under this warranty is limited to furnishing without additional charge a replacement or, at its option repairing or issuing credit for any product which shall within one year from the date of sale be returned freight prepaid to the plant designated by an Allied Machine representative and which upon inspection is determined by Allied Machine to be defective in materials or workmanship.

Complete information as to operating conditions, machine, set-up, and application of cutting fluid should accompany any product returned for inspection. The provisions of this warranty shall not apply to any Allied Machine products which have been subjected to misuse, improper operating conditions, machine set-up or application of cutting fluid or which have been repaired or altered if such repair or alteration in the judgment of Allied Machine would adversely affect performance of the product.

THIS WARRANTY IS IN LIEU OF ALL OTHER WARRANTIES, EXPRESS OR IMPLIED, INCLUDING ANY IMPLIED WARRANTY OF MERCHANTABILITY OR FITNESS FOR A PARTICULAR PURPOSE. Allied Machine shall have no liability or responsibility on any claim of any kind, whether in contract, tort or otherwise, for any loss or damage arising out of, connected with, or resulting from the manufacture, sale, delivery or use of any product sold hereunder, in excess of the cost of replacement or repair as provided herein.

ALL PRICES, DELIVERIES, DESIGNS, AND MATERIALS ARE SUBJECT TO CHANGE WITHOUT NOTICE.



Allied Machine & Engineering
Registered to ISO 9001
10001329

United States

Allied Machine & Engineering

120 Deeds Drive
Dover OH 44622
United States

Phone:
330.343.4283

Fax:
330.602.3400

Toll Free USA and Canada:
800.321.5537

Toll Free USA and Canada:
800.223.5140

Allied Machine & Engineering

485 W Third Street
Dover OH 44622
United States

Phone:
330.343.4283

Fax:
330.364.7666
(Engineering Dept.)

Toll Free USA and Canada:
800.321.5537

Europe

Allied Machine & Engineering Co. (Europe) Ltd.

93 Vantage Point
Pensnett Estate
Kingswinford
West Midlands
DY6 7FR England

Phone:
+44 (0) 1384 400900

Wohlhaupter GmbH

Maybachstrasse 4
Postfach 1264
72636 Frickenhausen
Germany

Phone:
011-49-7022-408-0

Fax:
011-49-7022-408-212

Asia

Wohlhaupter India Pvt. Ltd.

B-23, 2nd Floor
B Block Community Centre
Janakpuri, New Delhi - 110058
India

Phone:
+91-11-41827044

Your local Allied Machine representative:



www.alliedmachine.com

Allied Machine & Engineering is registered by DQS to ISO 9001 10001329

© 2017 Allied Machine & Engineering
Literature Order Number: A55-4TX
Publish Date: September 2017