



FILE BELT SANDER INSTRUCTION MANUAL

1/8-3/4 in. x 18-24 in. (3-19 mm x 457-610 mm)

22,000 RPM, 4990 SFPM (1521 smm)

Important Safety Information

Please read, understand and follow all safety information contained in these instructions prior to the use of this tool. Retain these instructions for future reference.

Intended Use

This pneumatic tool is intended for use in industrial locations, and used only by skilled, trained professionals in accordance with the instructions in this manual. This pneumatic tool is designed to be used with a contact arm and appropriate abrasive belts for sanding metals, wood, stone, plastics and other materials. It should only be used for such sanding applications and within marked capacity and ratings. Only accessories specifically recommended by 3M should be used with this tool. Use in any other manner or with other accessories could lead to unsafe operating conditions.

Do not operate tool in water or in an excessively wet application.

Explanation of Signal Word Consequences

	WARNING: Indicates a potentially hazardous situation which, if not avoided, may result in death or serious injury and/or property damage.
	CAUTION: Indicates a potentially hazardous situation which, if not avoided, may result in minor or moderate injury and/or property damage.

Read the Material Safety Data Sheets (MSDS) before using any materials.

Contact the suppliers of the workpiece materials and abrasive materials for copies of the MSDS if one is not readily available.

WARNING

Exposure to **DUST** generated from workpiece and/or abrasive materials can result in lung damage and/or other physical injury.

Use dust capture or local exhaust as stated in the MSDS. Wear government-approved respiratory protection and eye and skin protection.

Failure to follow this warning can result in serious lung damage and/or physical injury.



WARNING

To reduce the risks associated with impact from abrasive product, or tool breakup, sharp edges, hazardous pressure, rupture, vibration and noise:

- Read, understand and follow the safety information contained in these instructions prior to the use of this tool. Retain these instructions for future reference.
- Only personnel who are properly trained should be allowed to service this tool.
- Practice safety requirements. Work alert, have proper attire, and do not operate tools under the influence of alcohol or drugs.
- Operators and other personnel must always wear protection for eyes, ears, and respiratory protection when in the work area or while operating this product. Follow your employer's safety policy for PPE's and/or ANSI Z87.1 or local/national standards for eyewear and other personal protective equipment requirements.
- Wear protective apparel, taking into consideration the type of work being done.
- Never exceed marked maximum input pressure (90psi / .62Mpa / 6.2Bars).
- Proper eye protection must be worn at all times.
- Tool shall not be operated in the presence of bystanders.
- If you notice any abnormal noise or vibration when operating the tool, immediately discontinue its use and inspect for worn or damaged components. Correct or replace the suspect component. If abnormal noise or vibration still exists, return the tool to 3M for repair or replacement. Refer to warranty instructions.
- Never operate this tool without all safety features in place and in proper working order.
- Never over-ride or disable the safety features of the start-stop control such that it is in the on position.
- Make sure the tool is disconnected from its air source before servicing, inspecting, maintaining, cleaning, and before changing abrasive product.
- Prior to use, inspect abrasive product and accessories for possible damage. If damaged, replace with new abrasive product and accessories available from 3M.
- Only use accessories supplied or recommended by 3M.
- Never allow this tool to be used by children or other untrained people.
- Do not leave an unattended tool connected to air source.
- Use only with mounting hardware recommended by 3M; check with 3M for mounting hardware requirements.
- Prior to use, ensure guard is oriented to protect the operator from flying fragments and is properly secured.
- If the tool is jammed, shut off the tool, disconnect the air hose and ease it free. Ensure the abrasive product is correctly secured.
- Never operate this tool without all guards and safety features in place and in proper working order.

⚠ WARNING

To reduce the risks associated with vibration:

- If any physical hand/wrist discomfort is experienced, work should be stopped promptly to seek medical attention. Hand, wrist and arm injury may result from repetitive work, motion and overexposure to vibration.

To reduce the risks associated with loud noise:

- Always wear hearing protection while operating this tool. Follow your employer's safety policy or local/national standards for personal protective equipment requirements.

To reduce the risks associated with fire or explosion:

- Do not operate the tool in explosive atmospheres, such as in the presence of flammable liquids, gases, or dust. The abrasives are able to create sparks when working material, resulting in the ignition of the flammable dust or fumes.

- Refer to MSDS of material being worked as to potential for creating fire or explosion hazard.

To reduce the risks associated with hazardous dust ingestion or eye/skin exposure:

- Use appropriate respiratory and skin protection, or local exhaust as stated in the MSDS of the material being worked on.

To reduce the risks associated with hazardous voltage:

- Do not allow this tool to come into contact with electrical power sources as the tool is not insulated against electrical shock.

⚠ CAUTION!

To reduce the risks associated with skin abrasion, burns, cuts, or entrapment:

- Keep hands, hair, and clothing away from the rotating part of the tool.

- Wear suitable protective gloves while operating tool.

- Do not touch the rotating parts during operation for any reason.

- Do not force tool or use excessive force when using tool.

To reduce the risks associated with whipping or hazardous pressure-rupture:

- Ensure supply hose is oil resistant and is properly rated for required working pressure.

- Do not use tools with loose or damaged air hoses or fittings.

- Be aware that incorrectly installed hoses and fittings might unexpectedly come loose at any time and create a whipping/impact hazard.

To reduce the risks associated with fly off of abrasive product or parts:

- Use care in attaching abrasive product and mounting hardware; following the instructions to ensure that they are securely attached to the tool before use.

- Never point this product in the direction of yourself or another person, or start tool unintentionally.

- Never over-tighten accessory fasteners.

Parts Page

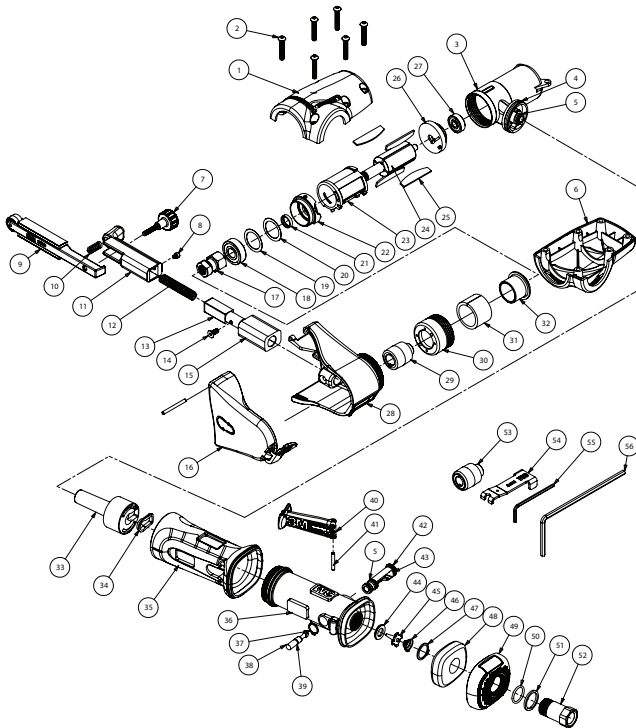

Parts List

ITEM	3M P/N	DESCRIPTION	QTY
1	30611	HOUSING - LEFT	1
2	30612	SOCKET BUTTON HEAD CAP SCREW - M4 x 25 mm	6
3	30613	MOTOR CASE	1
4	30614	O-RING - 31 mm x 34 mm	1
5	30615	O-RING - 8 mm x 10 mm	2
6	30616	HOUSING - RIGHT	1
7	30617	TRACKING / CONTROL KNOB	1
8	30618	SOCKET HEAD CAP SCREW - M3 x 5 mm	1
9	28368	*FILE BELT ARM STANDARD STYLE	1
10	30619	SPRING, TRACKING BIAS	1
11	30620	TRACKING ARM MOUNT	1
12	30621	SPRING - BELT TENSION	1
13	30622	TRACKING ARM POST	1
14	30623	FLAT HEAD SCREW - M4 x .07 10 mm	1
15	30624	DUST COVER	1
16	30625	BELT COVER AND LATCH ASSEMBLY	1
17	30626	DRIVE STUD ADAPTOR	1
18	30627	BEARING - 2 SHIELDS 10 mm x 26 mm x 8 mm	1
19	30628	SHIM - 25.4 mm OD x 19 mm ID x 0.02 mm THK	1
20	30629	SHIM - 25.4 mm OD x 19 mm ID x 0.05 mm THK	1
21	30630	SPACER - 13.4 mm OD x 10.01 mm ID x 3.2 THK	1
22	30631	ENDPLATE ASSEMBLY - FRONT	1
23	30632	CYLINDER	1
24	30633	ROTOR	1
25	30634	ROTOR VANE	4
26	30635	ENDPLATE ASSEMBLY - REAR	1
27	30636	BEARING - 2 SHIELDS 6 mm x 19 mm x 6 mm	1
28	30637	BELT HOUSING/GUARD	1
29	30638	DRIVE PULLEY	1
30	30639	FRONT EXHAUST MANIFOLD	1
31	30640	DIFFUSER	1
32	30641	MOTOR SPACER	1
33	30642	AIR GUIDE	1
34	30643	GASKET, AIR GUIDE	1
35	30644	HANDLE GRIP	1
36	30645	HANDLE	1
37	30646	RETAINING RING - $\frac{7}{16}$ in. DIAMETER	1
38	30647	VALVE STEM	1
39	30648	O-RING - 4 mm x 1.0 mm	1
40	30649	SAFETY LEVER ASSEMBLY SET	1
41	30650	SPRING PIN	1
42	30651	SPEED CONTROL	1
43	30652	O-RING - 9 mm x 1.5 mm	1
44	30653	VALVE SEAT	1
45	30654	VALVE	1
46	30655	VALVE SPRING	1
47	30656	RETAINING RING - $\frac{5}{8}$ in. DIAMETER	1
48	30657	DIFFUSER	1
49	30658	EXHAUST CAP WITH LABELS	1
50	30659	O-RING - 15.6 mm x 1.5 mm	1
51	30660	WASHER, AIR INLET	1
52	30661	INLET ADAPTOR	1
53	30671	DRIVE PULLEY - RUBBER	1
54	30672	WRENCH - DRIVE WHEEL	1
55	30674	WRENCH - 2.5 mm L-KEY	1
56	30673	WRENCH - 4.0 mm L-KEY	1

* See File Belt Contact Arm chart for additional arms

Product Configuration/Specifications: 22,000 RPM File Belt Sander

Model Number	Belt Size in. (mm)	Motor Speed (RPM)	Belt Speed SFPM (s/mm)	Product Net Wt lb (kg)	Height in. (mm)	Length in. (mm)	Width in. (mm)	*Noise Level dBA Pressure (Power)	**Vibration Level m/s ² (ft/s ²)	**Uncertainty K m/s ²
28366	¹ / ₈ - ³ / ₄ x 18-24 (3-19 x 457-610)	22,000	4990 (1521)	2.8 (1.3)	2.93 (74.5)	14.57 (370)	5.95 (151.2)	81 (90)	<2.5 (<8.2)	N/A

*Declared noise levels; measurements carried out in accordance with standard EN ISO 15744:2008.

** Declared vibration levels in accordance with EN12096; measurements carried out in accordance with standard EN ISO 28662-1:1992; EN 60745-1:2006 and EN 60745-2-4:2007, except that feed force was reduced to 10N +/- 5N due to the impracticality of operating this small tool at 30N +/- 5N as stated in the standard.

IMPORTANT NOTE: The noise and vibration values stated in the table are from laboratory testing in conformity with stated codes and standards and are not sufficient risk evaluation for all exposure scenarios. The actual exposure values and amount of risk or harm experienced to an individual is unique to each situation and depends upon the surrounding environment, the way in which the individual works, the particular material being worked, work station design, as well as upon the exposure time and the physical condition of the user. 3M™ cannot be held responsible for the consequences of using declared values instead of actual exposure values for any individual risk assessment.

Operating / Maintenance instructions

PRIOR TO THE OPERATION

The tool is intended to be operated as a hand held tool. It is always recommended that while using the tool, operators stand on a solid floor, in a secure position with a firm grip and footing. Be aware that the sander can develop a torque reaction. See the section "SAFETY PRECAUTIONS".

Use a clean lubricated air supply that will give a measured air pressure at the tool of 6.2 bar (90 psig) when the tool is running with the lever fully depressed. It is recommended to use an approved 10 mm (³/₈ in) x 8 m (25 ft) maximum length airline. Connect the tool to the air supply as shown in Figure 1. Do not connect the tool to the airline system without an easily accessible air shut off valve. It is strongly recommended that an air filter, regulator and lubricator (FRL) be used as shown in Figure 1 as this will supply clean, lubricated air at the correct pressure to the tool. In any case appropriate air pressure regulators shall be used at all times while operating this tool where the supply pressure exceeds the marked maximum of the tool. Details of such equipment can be obtained for your tool distributor. If such equipment is not used, the tool should be manually lubricated. To manually lubricate the tool, disconnect the airline and put 2 to 3 drops of suitable pneumatic motor lubricating oil such as 3M™ Air Tool Lubricant PN 20451, Fuji Kosan FK-20, Mobil ALMO 525 into the hose end (inlet) of the tool. Reconnect tool to the air supply and run tool slowly for a few seconds to allow air to circulate the oil. If the tool is used frequently, lubricate it on a daily basis or lubricate it if the tool starts to slow or lose power. It is recommended that the air pressure at the tool be 6.2 bar (90 psig) while the tool is running so the maximum RPM is not exceeded. The tool can be run at lower pressures but should never be run higher than 6.2 bar (90 psig). If run at lower pressure the performance of the tool is reduced.

Recommended Airline Size - Minimum		Recommended Maximum Hose Length		Air Pressure	
10 mm	3/8 in	8 meters	25 feet	Maximum Working Pressure 6.2 bar 90 psig	
				Recommended Minimum	NA NA

Safety Precautions

1. Read all instructions before using this tool. All operators must be fully trained in its use and aware of these safety rules.
2. The tool RPM should be checked on a regular basis to ensure proper operating speed.
3. Make sure the tool is disconnected from the air supply.
4. Always wear required safety equipment when using this tool.
5. Always remove the air supply to the tool before fitting, adjusting or removing the abrasive.
6. Always adopt a firm footing and grip and be aware of torque reaction developed by the tool.
7. Use only 3M approved spare parts.
8. Always ensure the material being worked is firmly fixed to avoid movement.
9. Check hose and fittings regularly for wear. Do not carry the tool by its hose; always be careful to prevent the tool from being started when carrying the tool with the air supply connected.
10. Dust can be highly combustible.
11. If tool is serviced or rebuilt, check to ensure that the maximum tool RPM is not exceeded and that there is no excessive tool vibration.
12. Do not exceed maximum recommended air pressure. Use safety equipment as recommended.
13. The tool is not electrically insulated. Do not use where there is a possibility of contact with live electricity, gas pipes, and/or water pipes.
14. This tool is not protected against hazards inherent in grinding and cutting operations and no such accessories should ever be attached.
15. Take care to avoid entanglement with the moving parts of the tool with clothing, ties, hair, cleaning rags or loose hanging objects. If entangled, stop air supply immediately to avoid contact with moving tool parts.
16. If the tool appears to malfunction, remove from use immediately and arrange for service and repair.
17. Immediately release the start handle in the event of any disruption of pressure; do not attempt to re-start until the disruption has been corrected.
18. When tool is not in use, store in a clean dry environment free of debris.
19. Recycle or dispose of tool according to Local, State, and Federal Regulations.

3M™ File Belt Contact Arms

3M Contact Arms are perfectly mated for use on the 3M File Belt Sander. Constructed from premium, industrial-quality materials, their durability and precise construction are the ideal complement to the performance of the 3M File Belt Sander. The following chart is a sample of products offered.

See 3M ASD Accessory catalog 61-5002-8098-9 for additional Accessories.

Service Tool Kit

Description	Part Number
Service Tool Kit	30670

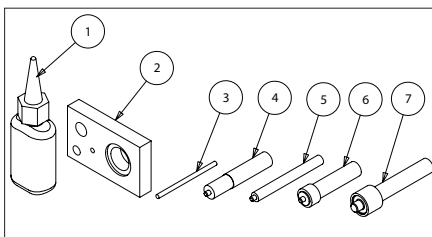

ITEM	DESCRIPTION	QTY.
1	RETAINING COMPOUND	1
2	WHEEL POSITION BLOCK	1
3	SHAFT REMOVAL TOOL	1
4	BEARING REMOVAL TOOL $\frac{3}{8}$ in. ID	1
5	BEARING REMOVAL TOOL $\frac{1}{4}$ in. ID	1
6	BEARING MOUNT TOOL	1
7	BEARING TOOL $\frac{5}{8}$ in. ID	1

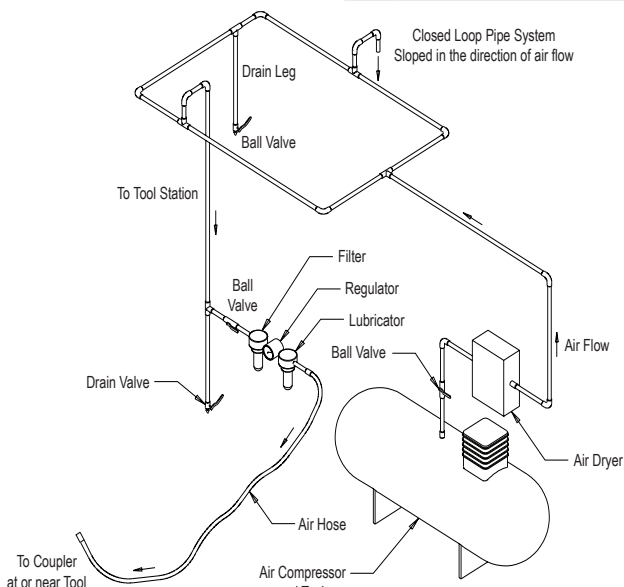
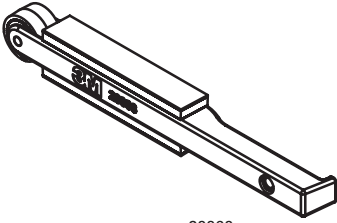
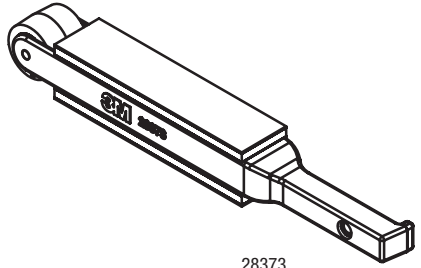

Figure 1

File Belt Contact Arms



28368



28373

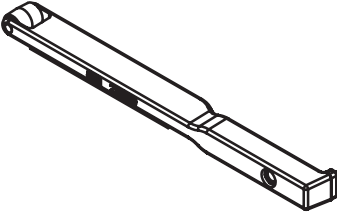

28369

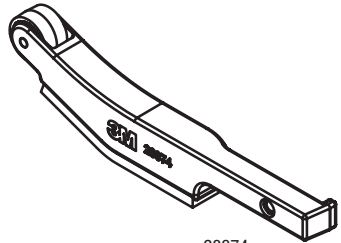

28374

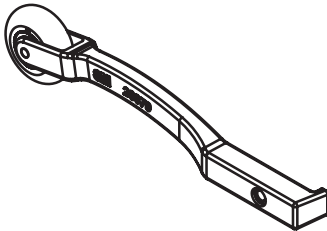

28370

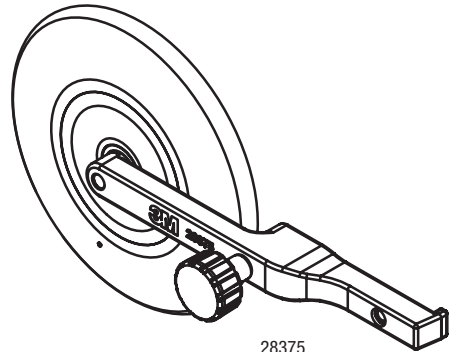

28375

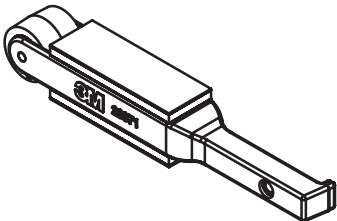

28371

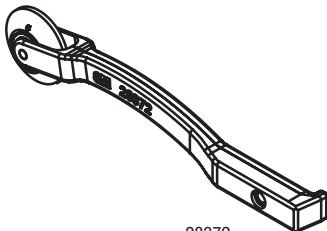

28372

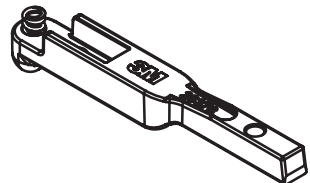

28376

File Belt Contact Arms

File Belt Arm Description	Arm P/N	Repair Kit P/N	Description	Qty
Thick Standard Style	28371	30664	Pad, Neoprene Platen $\frac{3}{4}$ in. Wide	2
			Wheel, Contact $\frac{3}{4}$ in. Dia x $\frac{5}{8}$ in. Wide	1
			Bearing, $\frac{3}{8}$ in. OD x $\frac{1}{8}$ in. ID x $\frac{5}{32}$ in. Wide	2
			Shaft, $\frac{1}{8}$ in. Dia x $\frac{3}{4}$ in. Lg, Bearing Contact Wheel	1
20 $\frac{1}{2}$ in. Arm	28373	30665	Pad, Cork Platen $\frac{3}{4}$ in. Wide	2
			Wheel, Contact $\frac{3}{4}$ in. Dia x $\frac{5}{8}$ in. Wide	1
			Bearing, $\frac{3}{8}$ in. OD x $\frac{1}{8}$ in. ID x $\frac{5}{32}$ in. Wide	2
			Shaft, $\frac{1}{8}$ in. Dia x $\frac{3}{4}$ in. Lg, Bearing Contact Wheel	1
Standard Style	28368	30663	Pad, Neoprene Platen $\frac{1}{2}$ in. Wide	2
			Wheel, Contact $\frac{5}{8}$ in. Dia x $\frac{3}{8}$ in. Wide	1
			Shaft $\frac{1}{8}$ in. Dia x $\frac{1}{2}$ in. Lg, Bearing Contact Wheel	1
			Bearing, $\frac{3}{8}$ in. OD x $\frac{1}{8}$ in. ID x $\frac{5}{32}$ in. Wide	2
Thin Style	28369	30667	Pad, Platen Cork $\frac{1}{2}$ in. Wide	1
			Bearing, $\frac{1}{4}$ in. OD x $\frac{1}{8}$ in. ID x $\frac{7}{64}$ in. Wide	2
			Wheel, Contact $\frac{5}{16}$ in. Dia x $\frac{3}{8}$ in. Wide	1
			Shaft $\frac{1}{8}$ in. Dia x $\frac{1}{2}$ in. Lg, Bearing Contact Wheel	1
Corners Style	28370	30668	Bearing, $\frac{3}{8}$ in. OD x $\frac{1}{8}$ in. ID x $\frac{5}{32}$ in. Wide	2
			Shaft $\frac{1}{8}$ in. Dia x $\frac{1}{2}$ in. Lg, Bearing Contact Wheel	1
			Wheel, Contact 1 in. Dia x $\frac{3}{8}$ in. Wide	1
Corners Style	28372	30666	Wheel, Contact 1 in. Dia x $\frac{3}{8}$ in. Wide	1
			Bearing, $\frac{3}{8}$ in. OD x $\frac{1}{8}$ in. ID x $\frac{5}{32}$ in. Wide	2
			Shaft $\frac{1}{8}$ in. Dia x $\frac{1}{2}$ in. Lg, Bearing Contact Wheel	1
Curved Arm	28374	30662	Pad, Platen Cork $\frac{1}{2}$ in. Wide	1
			Wheel, Contact $\frac{5}{8}$ in. Dia x $\frac{3}{8}$ in. Wide	1
			Bearing, $\frac{3}{8}$ in. OD x $\frac{1}{8}$ in. ID x $\frac{5}{32}$ in. Wide	2
			Shaft $\frac{1}{8}$ in. Dia x $\frac{1}{2}$ in. Lg, Bearing Contact Wheel	1
Vessel Arm	28375	30669	Washer	1
			Bearing, $\frac{5}{8}$ in. x $\frac{1}{4}$ in. x .196 in. wide	2
			Contact Wheel - 4 in.	1
			Screw, Soc Hd $\frac{1}{4}$ -28 x $\frac{3}{4}$ in.	1
Extension	28376	N/A	Spring, Tracking Bias	1
			Screw	1

Mounting and Removing Abrasive Belt

To Install/Remove Belt:

1. Disconnect the air line.
2. Flip the Belt Cover Latch up to release the Belt Cover.
3. Rotate the Belt Cover upward, exposing the Drive Pulley.
4. Pull back the Tracking Arm Mount to gain and hold slack in the belt.
5. Remove and replace the belt, then release the Tracking Arm Mount to regain tension in the belt.
6. Rotate the Belt Cover downward, and flip the Belt Cover Latch down, securing the Belt Cover.
7. Connect the air line.
8. Adjust belt tracking by turning the knob to the left or right as needed, while the machine is running.

Adjusting Belt Tracking

To Adjust Belt Tracking:

1. While the tool is running, turn the Tracking Knob to the left or right, so the abrasive belt runs centered over contact arm wheel. (See Fig. 2.)
2. Always apply the returning side of the belt to the workpiece to maintain proper tracking.

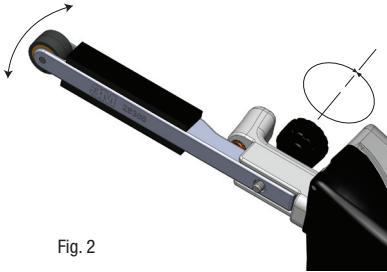

Fig. 2

Mounting and Removing Contact Arms

To Install/Change Contact Arm:

1. Disconnect the air line.
2. Flip the Belt Cover Latch up to release the Belt Cover.
3. Rotate the Belt Cover upward, exposing the Drive Pulley.
4. Pull back the Tracking Arm Mount to gain and hold slack in the belt.
5. Remove the belt.
6. Remove the Tracking Knob.
7. Remove the Contact Arm and replace with the desired arm. Make sure the tab on the end of the arm is in the channel of the Tracking Arm Mount. (See Fig. 3.)
8. Replace the Tracking Knob and tighten it into the threaded hole on the Contact Arm so the Contact Arm is as straight as possible.
9. Install the abrasive belt and secure the Belt Cover.
10. Connect the air line and adjust belt tracking by turning the Tracking Knob as needed while the machine is running.

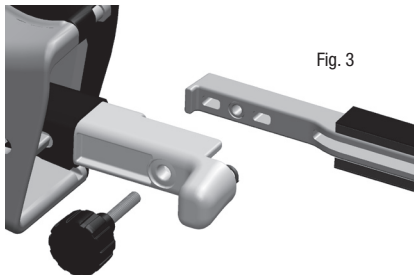

Fig. 3

Adjusting Belt Housing and Handle Position

To Adjust Belt Housing Position:

1. Disconnect the air line.
2. Loosen M4 cap screws "A" and "B": (See Fig. 4.)
3. Rotate the Belt Housing to the desired position. Detents indicate the positions within a 360 degree range.
4. Tighten M4 cap screws "A" and "B":

To Adjust Handle/Lever Position:

1. Disconnect the air line.
2. Loosen M4 cap screws "B" and "C": (See Fig. 4.)
3. Rotate the Handle/Lever to the desired position. Detents indicate the positions within a 360 degree range.
4. Tighten M4 cap screws "B" and "C":

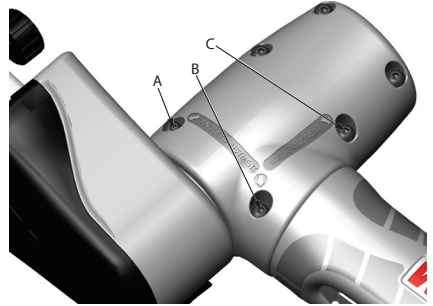

Fig. 4

Product Use: All statements, technical information and recommendations contained in this document are based upon tests or experience that 3M believes are reliable. However, many factors beyond 3M's control can affect the use and performance of a 3M product in a particular application, including the conditions under which the 3M product is used and the time and environmental conditions in which the product is expected to perform. Since these factors are uniquely within the user's knowledge and control, it is essential that the user evaluate the 3M product to determine whether it is fit for a particular purpose and suitable for the user's method of application.

Warranty and Limited Remedy: 3M warrants this tool against defects in workmanship and materials under normal operating conditions for one (1) year from the date of purchase. 3M MAKES NO OTHER WARRANTIES, EXPRESS OR IMPLIED, INCLUDING, BUT NOT LIMITED TO, ANY IMPLIED WARRANTY OF MERCHANTABILITY OR FITNESS FOR A PARTICULAR PURPOSE OR ANY IMPLIED WARRANTY ARISING OUT OF A COURSE OF DEALING, CUSTOM OR USAGE OF TRADE. User is responsible for determining whether the 3M tool is fit for a particular purpose and suitable for user's application. User must operate the tool in accordance with all applicable operating instructions, safety precautions, and other procedures stated in the operating manual to be entitled to warranty coverage. 3M shall have no obligation to repair or replace any tool or part that fails due to normal wear, inadequate or improper maintenance, inadequate cleaning, nonlubrication, improper operating environment, improper utilities, operator error or misuse, alteration or modification, mishandling, lack of reasonable care, or due to any accidental cause. If a

tool or any part thereof is defective within this warranty period, your exclusive remedy and 3M's sole obligation will be, at 3M's option, to repair or replace the tool or refund the purchase price.

Limitation of Liability: Except where prohibited by law, 3M and seller will not be liable for any loss or damage arising from the 3M product, whether direct, indirect, special, incidental or consequential, regardless of the legal theory asserted, including warranty, contract, negligence or strict liability.

Submitting a Warranty Claim: Contact your dealer when submitting a warranty claim in accordance with the restrictions listed above. Please note that all warranty claims are subject to manufacturer's approval. Be sure to keep your sales receipt in a safe place. This must be submitted when filing a warranty claim, within 1 year from the date of purchase. For additional assistance call 1-800-362-3550.

Product Repair after Warranty Has Expired: Repair of 3M Abrasive Power tools that are not under warranty is available through 3M or a 3M Authorized Tool Repair Representative. Contact your 3M Abrasive Power Tool Distributor for details, or call 1-800-362-3550.

EC Declaration of Conformity



Manufacturers Name: 3M, Abrasive Systems Division
Manufacturers Address: 3M Center, Building 223-6N-02
 St Paul, MN USA 55144

Does hereby declare that the machinery described below complies with those applicable essential health and safety requirements of the Machinery Directive 2006/42/EC; together with all amendments to date.

Description: 3M™ File Belt Sander, 1/8-3/4 in x 18-24 in (3-19 mm x 457-610 mm), 22,000 RPM, 4990 SFPM (1521 smm); Packaged as tool alone or in "kit" form with accessories

Model Number: 28366 (tool alone), 28367 (kit)

The following standards have either been referred to, or complied with, in full or in part as relevant:

EN ISO 12100-1:2003	Safety of machinery. Basic concepts, general principles for design – Basic terminology and Technical principals
EN ISO 12100-2:2003	Hand-held non-electric power tools – Safety Requirements – Part 8: Sanders and Polishers
EN 792-8:2001 A1:2008	Safety of machinery. Safety requirements for fluid power systems and components - Pneumatics
EN 983:1996	Safety of machinery. Risk assessment principles
EN ISO 14121-1:2007	Hand-held portable power tools – Measurement of vibrations at the handle – Part 1: General
EN ISO 28662-1:1992	Hand-held motor-operated electric tools. Safety. General requirements
IEC EN 60745-1:2006*	Hand-held motor-operated electric tools. Safety. Particular requirements for sanders and polishers other than disk type
IEC EN 60745-2-4:2003 A1:2007*	Hand-held non-electric power tools. Noise measurement code. Engineering method (grade 2)
EN ISO 15744:2008	

*applied for vibration measurements only; reduced feed force – refer to product specifications.

Full Name of responsible person:

Stefan A. Babirad

Position: Technical Director

Signature: 

Date: 

St. Paul, Minnesota, USA

3M
 Abrasive Systems Division
 3M Center
 St. Paul, MN 55144-1000
 www.3M.com/abrasives

© 3M 2010
 3M is a trademark of 3M Company